

**MEGGER VOLTAGE AND CURRENT TRANSFORMER TEST
INSTRUMENT
MVCT USER MANUAL**

**May 8, 2020
Part#86027R5**

Table of Contents

1.0	MVCT.....	12
1.0	Introduction.....	12
1.2	Terminology.....	12
1.2.1	Acronyms	12
2.0	MVCT Unpack and Preparation for Use.....	13
2.1	Contents of MVCT kit.....	13
2.2	Assembly and Installation.....	15
2.3	Communication Ports	15
2.3.1	Ethernet Ports on MVCT	15
2.3.2	Ethernet Ports on Display	16
2.3.3	USB 2.0 Interface on Display	16
2.4	Supply Voltage	16
2.5	Operating System.....	17
3.0	Basic Theory of Operation.....	17
3.1	General	17
3.2	CT Testing	17
3.2.1	Ratio Test	17
3.2.2	Polarity Test	18
3.2.3	Excitation Test.....	20
3.2.4	Insulation Resistance Test.....	21
3.2.5	Burden Test	22
3.2.6	Secondary Winding Resistance	23
4.0	Powering System	23
4.1	Initial Start Up.....	23
5.0	User Interface	24
5.1	Integrated Display or Smart Touch View Interface.....	24
5.2	Personal Computer Interface.....	25
5.3	Software Interface.....	29
5.4	Testing Mode.....	32
5.4.1	CT Testing Mode – Menu Items.....	32
5.4.2	VT Testing Mode – Menu Items	64
5.4.2.7	Self Test.....	72
5.4.3	Relay Testing Mode.....	81
6.0	Testing CT with MVCT	82
6.1	Test Plan Creation	82
6.2	CT Saturation Test.....	86
6.2.1	Method 1 – Concurrent.....	86
6.2.2	Method 2 – Non Concurrent or Testing a Single Tap.....	90
6.3	Ratio Test	94
6.3.1	Method 1 – Concurrent.....	94
6.3.2	Method 2 – Non Concurrent or Testing a Single Tap.....	98
6.4	CT Winding Resistance Test:.....	103
6.4.1	Method 1 – Concurrent.....	103
6.4.2	Method 2 – Non Concurrent or Testing a Single Tap.....	107

6.5	Insulation Test:.....	111
6.6	Burden Test.....	114
6.7	Manual Test.....	118
6.8	Demagnetization.....	121
6.9	Self Test.....	123
7.0	Testing VT's with MVCT.....	125
7.1	Running a Complete Test of VT and Test Plan Creation.....	125
7.2	Testing VT Ratio and Phase.....	131
7.3	Testing Voltage Transformer – Saturation/Excitation Test.....	135
7.4	Testing Voltage Transformer Winding Resistance :.....	138
7.5	Testing Voltage Transformer: Secondary Short Circuit Impedance.....	141
7.6	Testing Voltage Transformer : Demagnetization.....	145
7.7	Testing Voltage Transformer: Self Diagnostic.....	147
8.0	Testing Relays with MVCT.....	149
9.0	Service Data.....	149
9.1	Preventive Maintenance.....	149
9.1.1	Examine the unit every six months for:.....	150
9.1.2	Upgrading Software.....	150
9.2	Service and Repair Instructions.....	151
9.2.1	Basic Troubleshooting.....	151
10.0	Preparation for Reshipment.....	152
	Appendix I CTs Mounted on Transformer Bushings.....	154
	Appendix II Testing CT in Reactor.....	157
	Appendix III CTs Inside Delta Connection.....	159

List of Figures

Figure 1 Ethernet Ports	16
Figure 2 Ethernet Port to Power Display	16
Figure 3 USB Port.....	16
Figure 4 Initial Screen.....	24
Figure 5 Instrument Connection Screen	25
Figure 6 Boot Up Home Screen.....	25
Figure 7 PowerDB Lite Initial Screen	26
Figure 8 Instrument Configuration Dialog	27
Figure 9 Form Selection Dialog.....	27
Figure 10 Instrument Logon Screen	28
Figure 11 Connection Dialog.....	28
Figure 12 PowerDB Lite Home Screen	29
Figure 13 Device Settings – CT Testing.....	33
Figure 14 Name Plate Data – CT Testing Mode.....	36
Figure 15 Home Screen CT Testing	38
Figure 16 Run All Test Screen.....	39
Figure 17 Manual Test Screen	40
Figure 18 Manual Test Connection Diagram.....	42
Figure 19 Manual Test Example.....	44
Figure 20 Demagnetization Connection Diagram	45
Figure 21 Demagnetization Process.....	46
Figure 22 Self Test Connection Diagram	47
Figure 23 Saturation Test Screen	48
Figure 24 Ratio Test Screen.....	49
Figure 25 Winding Resistance Test Screen	51
Figure 26 Insulation Resistance Test Screen	53
Figure 27 Burden Test Screen.....	54
Figure 28 Sample CT Test Report	55
Figure 29 Sample Multi Tap Test Report	57
Figure 30 Ratio and Phase Error Tables	58
Figure 31 Report Tap Configuration Dialog.....	59
Figure 33 Excitation Curve Data	60
Figure 34 View Excitation Data Points	61
Figure 35 File Operation Tool Bar.....	61
Figure 36 File Manager Screen.....	62
Figure 37 File Operations Using PC.....	63
Figure 38 File Save Using PC.....	64
Figure 39 Device Settings – VT Testing.....	64
Figure 40 Name Plate Data – VT Testing Mode	67
Figure 41 Home Screen VT Testing Mode.....	69
Figure 42 Run All Test Screen.....	70
Figure 43 Demagnetization Connection Diagram	71
Figure 44 Demagnetization Process.....	72
Figure 45 VT Ratio Test Screen	73
Figure 46 Saturation Test Screen	74

Figure 47 VT Winding Resistance Test Screen	75
Figure 48 Short Circuit Impedance Test Screen	76
Figure 49 Sample VT Test Report	77
Figure 50 Testing - File Operation Tool Bar	78
Figure 51 VT Testing: File Manager Screen	79
Figure 52 VT Testing: File Save from PC	81
Figure 53 Relay Testing System Log On.....	81
Figure 54 Relay Testing Screen	82
Figure 55 Run All Tests – Configuration	83
Figure 56 Test Plan - Multi Tap.....	84
Figure 57 CT Connection Diagram Multi Tap: Concurrent	85
Figure 58 CT Saturation Testing Screen: Concurrent.....	85
Figure 59 CT Test Report - Concurrent.....	86
Figure 60 CT Saturation Test Screen - Concurrent	88
Figure 61 CT Saturation Connection Diagram - Concurrent.....	88
Figure 62 CT Saturation Testing Screen – Concurrent.....	89
Figure 63 CT Saturation Results Screen - Concurrent.....	90
Figure 64 CT Saturation Test Screen – Non Concurrent.....	91
Figure 65 CT Saturation Connection Diagram - Non Concurrent.....	92
Figure 66 CT Saturation Test Screen Non Concurrent.....	93
Figure 67 CT Ratio Test Screen – Concurrent.....	95
Figure 68 CT Ratio Connection Diagram - Concurrent.....	96
Figure 69 CT Ratio Test Abort	97
Figure 70 CT Ratio Test Results - Concurrent	98
Figure 71 CT Ratio Test Screen – Non Concurrent.....	100
Figure 72 CT Ratio Test Connection Diagram - Non Concurrent.....	101
Figure 73 CT Ratio Testing Screen - Abort.....	102
Figure 74 CT Ratio Test Results – Non Concurrent.....	103
Figure 75 CT Winding Test Screen – Concurrent	105
Figure 76 CT Winding Connection Diagram – Concurrent.....	105
Figure 77 CT Winding Test ABORT.....	106
Figure 78 CT Winding Results - Concurrent.....	107
Figure 79 CT Winding Test Screen – Non Concurrent	108
Figure 80 CT Winding Resistance Connection Diagram Non Concurrent.....	109
Figure 81 CT Winding Test Screen –Abort.....	110
Figure 82 CT Winding Results - Non Concurrent	110
Figure 83 CT Insulation Test Screen	112
Figure 84 CT Insulation Test Connection Diagram.....	113
Figure 85 CT Insulation Testing Screen	113
Figure 86 CT Insulation Test Results	114
Figure 87 CT Burden Test Screen	115
Figure 88 CT Burden Test Connection Diagram.....	116
Figure 89 CT Burden Test Abort.....	117
Figure 90 CT Burden Test Results Screen.....	117
Figure 91 CT Manual Test Screen	119
Figure 92 CT Manual Test Connection Diagram	120

Figure 93 CT Demagnetization Connection Diagram	122
Figure 94 CT Demagnetizing Process Screen	123
Figure 95 CT Self Diagnostic Connection Diagram.....	124
Figure 96 CT Self Diagnostic Test Screen	125
Figure 97 VT Test Plan Screen.....	126
Figure 98 VT Connection Diagram for Winding Resistance.....	128
Figure 99 VT Winding Resistance Abort	128
Figure 100 VT Demagnetization	129
Figure 101 VT Saturation/Excitation Test.....	129
Figure 102 VT Short Circuit Impedance Connection Diagram	130
Figure 103 VT Ratio Test Connection Diagram.....	130
Figure 104 Sample VT Test Report	131
Figure 105 VT Ratio Test Screen	133
Figure 106 VT Ratio Test Connection Diagram.....	133
Figure 107 VT Ratio Testing Screen	134
Figure 108 VT Ratio Test Results	135
Figure 109 VT Saturation Test Screen.....	136
Figure 110 VT Saturation Connection Diagram.....	137
Figure 111 VT Saturation Test Screen.....	138
Figure 112 VT Winding Test Screen	139
Figure 113 VT Winding Resistance Connection Diagram	140
Figure 114 VT Winding Test Screen –Abort.....	141
Figure 115 VT Winding Results	141
Figure 116 VT Secondary Short Circuit Impedance Test Screen.....	142
Figure 117 VT Short Circuit Impedance Connection Diagram	143
Figure 118 VT Short Circuit Impedance –Abort	144
Figure 119 VT Short Circuit Impedance Results.....	144
Figure 120 VT Demagnetization Connection Diagram	146
Figure 121 VT Demagnetization Screen –Abort	147
Figure 122 Self Diagnostic Connection Diagram.....	148
Figure 123 Self Diagnostic Test Screen.....	149

IMPORTANT

This manual, as well as the hardware and software described in it, is furnished under license and may be used or copied only in accordance with the terms of such license. The content of this manual is furnished for informational use only, is subject to change without notice. Megger assumes no responsibility or liability for any errors or inaccuracies that may appear in this manual.

The information and data in this User Manual are proprietary. The equipment described herein may be protected by U.S. patents. Megger specifically reserves all rights to such proprietary information as well as rights under any patent, none of which is waived by the submission of this user manual.

Except as permitted by such license, no part of this publication may be reproduced, stored in a retrieval system, or transmitted, in any form or by any means, electronic, mechanical, recording, or otherwise, without the prior written permission of Megger.

Megger, the Megger logo are trademarks of Megger. All other trademarks are the property of their respective owners.

Notice to U.S. government end users. The hardware, software and documentation are "commercial items", as that term is defined at 48 C.F.R. §2.101, consisting of "commercial computer software" and "commercial computer software documentation," as such terms are used in 48 C.F.R. §12.212 or 48 C.F.R. §227.7202, as applicable. Consistent with 48 C.F.R. §12.212 or 48 C.F.R. §§227.7202-1 through 227.7202-4, as applicable, the commercial computer software and commercial computer software documentation are being licensed to U.S. government end users (1) only as commercial items and (2) with only those rights as are granted to all other end users pursuant to the terms and conditions set forth in the Megger standard commercial agreement for this software and hardware. Unpublished rights reserved under the copyright laws of the United States. The recipient, if a Government agency, acknowledges that this manual and the equipment described were procured with "Limited Rights" to technical data as described in ASPR 9-203 (b).

The STVI includes an RTOS-resident computer program. This program belongs to Megger and contains trade secret ideas and information of Megger.

Written and designed at Megger, 4271 Bronze Way, Dallas, Texas 75237.

Printed in the USA.










© 2013 Megger, all rights reserved.

SAFETY PRECAUTIONS

WARNING:

VOLTAGES GENERATED BY THIS INSTRUMENT CAN BE HAZARDOUS

This instrument has been designed for operator safety; however, no design can completely protect against incorrect use. Electrical circuits are dangerous and can be lethal when lack of caution and poor safety practices are used. There are several standard safety precautions that should be taken by the operator. Where applicable, IEC safety markings have been placed on the instrument to notify the operator to refer to the user manual for instructions on correct use or safety related topics. Refer to the following table of symbols and definitions.

Symbol	Description
	Direct Current
	Alternating Current
	Both direct and alternating current
	Earth (ground) Terminal. There is a common chassis ground terminal located on the front panel (see Front panel under Description of Controls).
	Protective Conductor Terminal
	Frame or Chassis Terminal
	On (Supply)
	Off (Supply)
	Caution, risk of electric shock



Caution (refer to accompanying documents)

⚠ WARNING: Under no circumstances should the operator or technician attempt to open or service any Megger instrument while connected to a power source. Lethal voltages are present and may cause serious injury or death! SAFETY PRECAUTIONS (Continued)

The following are some specific safety related items associated with the MVCT test system.

Read and understand all safety precautions and operation instructions before attempting to use this unit.

The purpose of this equipment is limited to use as described in this instruction manual. Should a situation arise that is not covered in the general or specific safety precaution please contact Megger regional representative or Megger, Dallas Texas.

Safety is the responsibility of the user. Misuse of this equipment can be extremely dangerous.

Always start with the power OFF, before connecting the power cord. Make sure outputs are off before attempting to make test connections.

DO NOT attempt to connect the test set to energized equipment.

DO NOT attempt to connect the test set to Current Transformers unless the Primary Side of the Current Transformer is grounded.

Always use properly insulated test leads. The optional test leads are rated for the continuous output ratings of the test system, and should be properly used and cared for. DO NOT use cracked or broken test leads.

Always turn the test system off before disconnecting the power cord.

DO NOT attempt to use the unit without a safety ground connected.

DO NOT attempt to use the unit if the power cord ground prong is broken or missing.

DO NOT use the test set in an explosive atmosphere.

The instrument must only be used by suitably trained and competent persons.

Observe all safety warnings marked on the equipment.

For safety related or other important topics, like the statement below, will be notated with the adjoined symbol. Read the topic carefully as it may relate either to the safe operation of the test system or the safety of the operator.



Under no circumstances should the operator put their hand or tools inside the test system chassis area with the test system connected to a power source. Lethal voltages are present and may cause serious injury or death!

WEEE

The crossed out wheeled bin placed on Megger products is a reminder not to dispose of the product at the end of its life with general waste.

Megger is registered in the UK as a Producer of Electrical and Electronic Equipment. The Registration No is WEE/HE0146QT

IEC Enclosure Rating: IP20

Megger

1.0 MVCT

1.0 Introduction

The Megger MVCT test set is a lightweight, robust, portable unit used to automatically or manually test both voltage and current transformers. For inductive VT, the MVCT is capable of performing saturation, ratio, secondary winding resistance, secondary short circuit impedance and various insulation tests. The MVCT is also capable of performing saturation, ratio, polarity, winding resistance, demagnetizing tests and insulation tests on current transformers. The MVCT provides a microprocessor controlled variable voltage and current output and precision instrumentation for automatically testing single and multi-ratio CTs and VT's reducing testing time and increasing productivity. The MVCT will directly connect to multi ratio CT's and perform all tests – saturation, ratio and polarity, winding resistance, and insulation – on all taps with the push of a button and without changing leads. The MVCT can be controlled via an integrated large, full color, high resolution, TFT LCD touch screen which allows the user to perform manual and automatic testing quickly and easily using the manual test screens, as well as using pre-constructed test routines. The large color display permits the user to easily read all pertinent data while the test is being performed and provides the ability to view the current transformer's saturation curve. The MVCT can also be configured to come without a display and be controlled via a laptop. Both current transformers and voltage transformers can be tested in their equipment configuration, such as being mounted in transformers, oil circuit breakers or switchgear. It is necessary for the equipment to be completely isolated from the electrical system prior to testing.

1.2 Terminology

The acronyms, terms, and definitions used throughout this manual are described below:

1.2.1 Acronyms

AC	Alternating Current
CW	Clockwise (rotation)
CCW	Counter Clockwise (rotation)
CT	Current Transformer
DC	Direct Current
GPS	Global Position System
GUI	Graphical User Interface
Hz	Hertz

ID	Identification
I/O	Input/Output
kHz	Kilo Hertz
LCD	Liquid Crystal Display
LED	Light Emitting Diode
MAG	Magnitude
PC	Personal Computer
ROM	Read-Only Memory
STVI	Smart Touch View Interface
USB	Universal Serial Bus
VIGEN	Voltage / Current Generator Module
VRMS	Volts Root Mean Square
VT	Voltage Transformer
UUT	Unit Under Test

2.0 MVCT Unpack and Preparation for Use

2.1 Contents of MVCT kit

After unpacking the unit and check for evidence of any shipping damage. If there is any visual damage, immediately notify the freight carrier to make a damage claim, and notify Megger of the damage.

Contents within the shipping container will vary depending upon how the MVCT was configured. Below is a complete list of all accessories available with the MVCT. Please check the order and the configuration of your MVCT to confirm which accessories should be included with your instrument.

Item (Qty.)	Cat No.
MVCT Voltage and Current Transformer Test Instrument	MVCT
CT Test Accessories (Standard Leads)	

Test Lead, H1 and H2 40ft. (1ea.)	1009-515
Test Lead, X1 to X5, 20ft., (1ea.)	1009-332
VT Test Accessories (VT Leads)	
VT Test Lead, Primary Side 40ft. (1ea.)	620149
Test Accessories (Included Any Configuration)	
Line cord, North America (1ea.)	90015-267
Or Line cord, International color coded wire (1ea.)	90015-267
Gnd lead, green with yellow, with large ground clip, 20ft., (1ea)	620151
Large Test clip, red, 40mm opening, (1ea.)	640266
Large Test clip, black, 40mm opening, (1ea.)	640267
Alligator clip, black, 4.1 mm, (1ea.)	9004-267
Cable Spade/Lug Adapter small (5 ea.)	684004
Cable Spade/Lug Adapter large (5 ea)	684003
Soft side lead case	90004-427
Soft side clip case	90001-165
USB memory stick	830029
Instruction book	750025
Power DB Lite	544342

Check the equipment received against the packing list to ensure that all the materials are present. Notify Megger of any shortages. Telephone 1-800-723 2861 and ask for Dallas customer service department.

Again if damage received in transit is discovered, file a claim with the carrier at once and notify Megger or its nearest authorized sales representative, giving a detailed description of the damage.

Megger warrants the product is free of defects in material and workmanship for a period of one (1) year from date of shipment. This warranty is non-transferable. This warranty is limited and shall not apply to equipment that has damage, or cause of defect, due to accident, negligence, and improper operation, faulty installation by the purchaser, or improper service or repair by any person, company or corporation not authorized by Megger. Megger will, at its' option, either repair or replace those parts and/or materials it deems to be defective.

The warranty is in lieu of all other warranties, either expressed or implied on the part of Megger and in no event shall Megger be liable for the consequential damages due to the breach thereof.

2.2 Assembly and Installation

The MVCT has been thoroughly tested and inspected to meet rigid specifications before being shipped. The unit is ready for use without any need of assembly or any installation procedure. Follow the instructions in this manual to understand the controls and operations of the unit before setting it up for performing the tests.

The MVCT can be ordered either with or without an integrated display. If no display was ordered then the unit may be controlled using a PC and the included software. The MVCT ordered with a display will have an 10 inch TFT Color Display integrated into the lid – this touch panel display provides high resolution, and features Wide Viewing Angle Technology with high luminance for reading in direct sunlight. The control knob is located on the front panel. During manual testing this knob will adjust values once the box location of the value to be changed is selected.

Power Over Ethernet Input Power

The integrated display gets Power Over Ethernet (PoE) of 48 Volts DC at 0.5 A from the MVCT.



CAUTION:

NOTE: The PoE power supply DC voltage is ON when the power supply is connected to a power source. Connect the Ethernet cable to the Data & Power Out port of the PoE power supply to the display Ethernet port prior to connecting to a power source.

2.3 Communication Ports

There are two types of communication ports on the MVCT, three Ethernet, and one USB ports. The Ethernet Ports are a 10/100BaseTX port. These ports supports MDI/MDI-X auto cross over configuration, which means both standard and “crossover” Ethernet cables

2.3.1 Ethernet Ports on MVCT

There is one Ethernet port on the MVCT for connecting the integrated display or a Megger STVI to the unit. On the MVCT this port is labeled STVI. This port contains the PoE power supply, and will provide power to either the display or an STVI. The IN port on the MVCT may be used to interconnect multiple SMRT units together for synchronous multi-phase operation.. The third Ethernet port label PC is the primary PC connection port

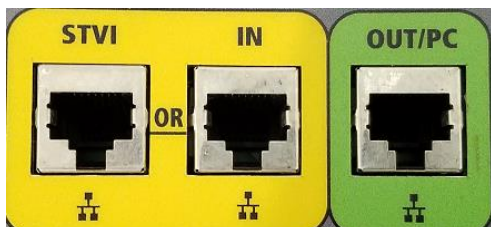


Figure 1 Ethernet Ports

2.3.2 Ethernet Ports on Display

There is one Ethernet port on the display module integrated into the MVCT's lid. This port is used to connect the display to MVCT unit and as noted earlier this connection supplies operating voltage to the display module. The display should be connected using the supplied cable to the STVI port located on the MVCT unit itself.

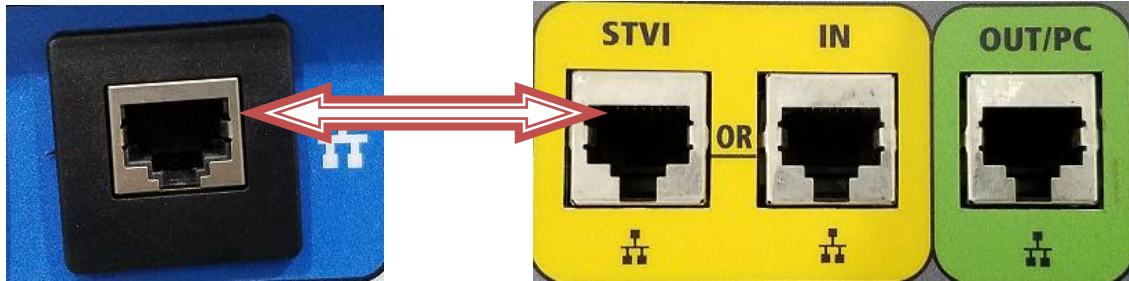


Figure 2 Ethernet Port to Power Display

2.3.3 USB 2.0 Interface on Display

There is one USB 2.0 Interface port on the MVCT display unit mounted in the lid. This port is used for upgrading firmware to the MVCT unit, or upgrading the PowerDB software using a USB Memory Stick. It may also be used in conjunction with a USB mouse for ease of manual control, even a USB wireless mouse maybe used with the display.



Figure 3 USB Port

2.4 Supply Voltage

Unit operates on a single phase AC power source .The input operating voltage should be between the following limits.

95-265 V 50-60 Hz 15A max.

Please refer to Input power precautions in safety section for detailed description of input power requirements.

2.5 Operating System

Unit works on Windows operating system.

3.0 Basic Theory of Operation

3.1 General

The purpose of this section is to explain the basic theory of the following tests and to guide the operator for making appropriate measurements with the MVCT. The following tests can be performed by the MVCT.

3.2 CT Testing

3.2.1 Ratio Test

The ratio is defined as the number of turns in the secondary as compared to the number of turns in the primary.

The purpose of ratio test is to prove the ratio of the CT, is as specified and also to verify the ratio at different taps of a multi tap CT. The turns ratio is equivalent to the voltage ratio and can be expressed as:

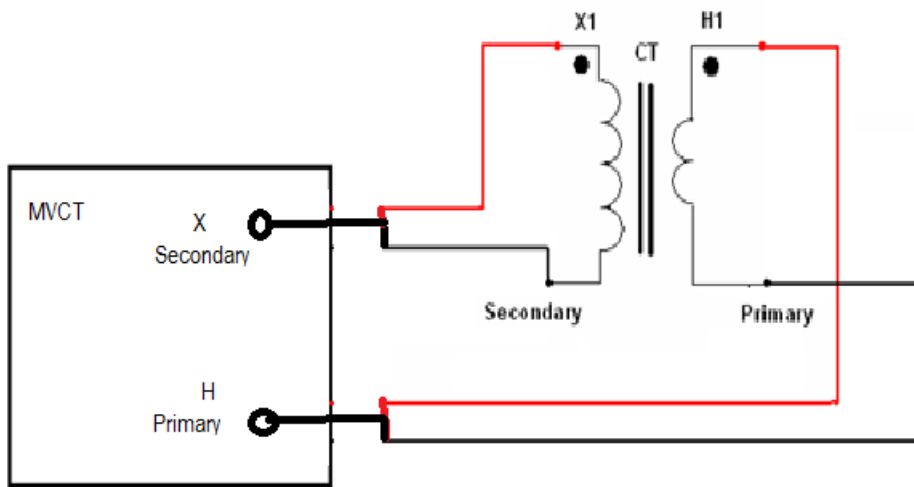
$$N2/N1=V2/V1$$

Where,

N2 and N1 are no. of turns of secondary and primary windings respectively

V2 and V1 are the secondary and primary side voltage readings respectively.

A suitable voltage, below saturation is applied to the secondary of the CT under test and primary side voltage is measured to calculate the turns ratio from above expression.



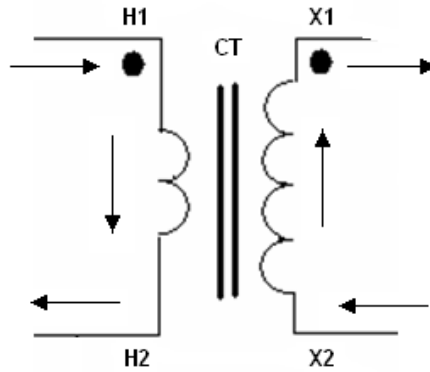
The MVCT performs the ratio test by either selecting Ratio test in the Run All test configuration or using the ratio test screen. User can also select manual Ratio test by selecting manual option and controlling the secondary applied voltage.

CAUTION

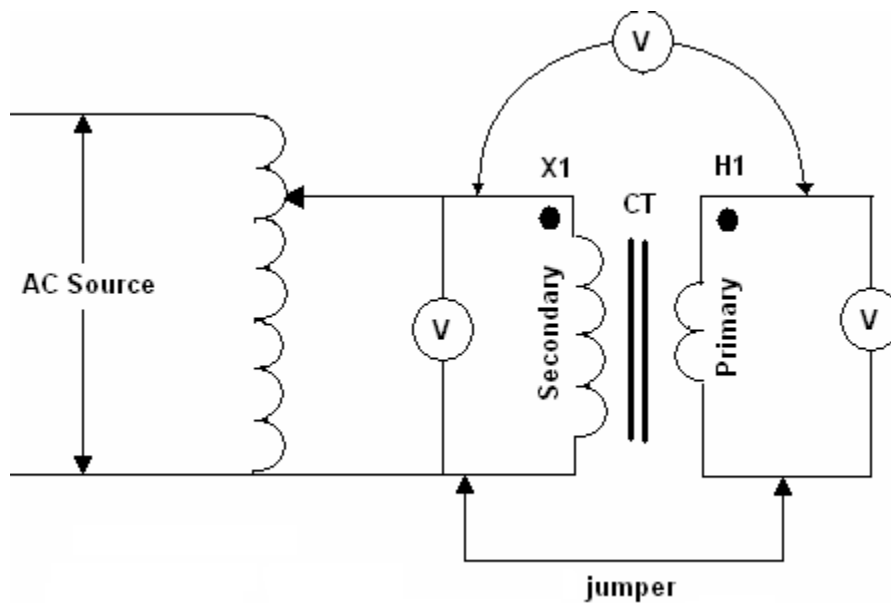
In the ratio test screen or the manual operation, do NOT apply the voltage high enough to the secondary of CT that would cause the CT to saturate; otherwise the readings will not be accurate.

3.2.2 Polarity Test

The Polarity test proves that the predicted direction of secondary CT current (leaving) is correct for a given direction of primary current (entering).



Polarity marks designate the relative instantaneous directions of the currents. At the same instant of time that the primary current is entering the primary terminal the corresponding secondary current is leaving the similarly marked secondary terminal. A CT under test is supposed to have correct polarity if instantaneous current direction for primary and secondary current is opposite to each other.



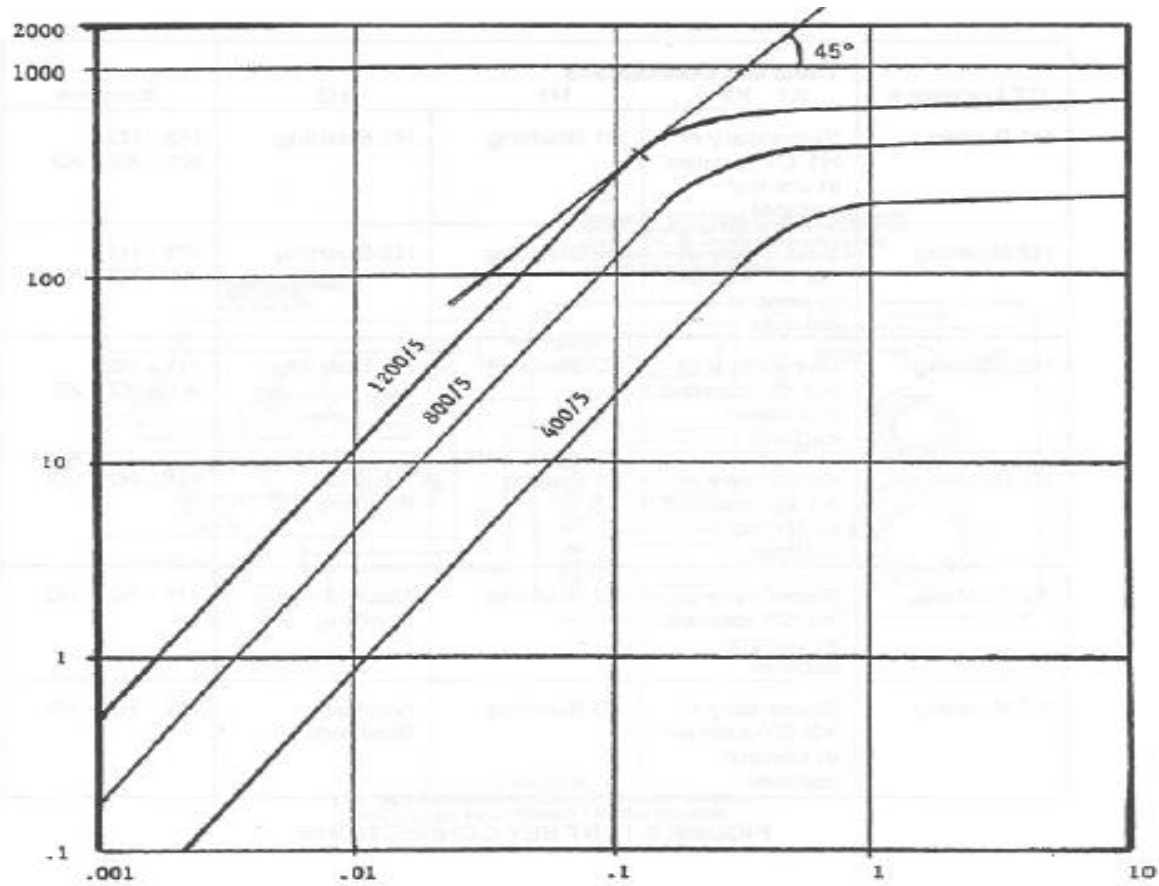
Same connection settings as for Ratio test can be used for performing Polarity test. The two non polarity marks are shorted together internally and potential is measured across the two polarity mark points. For correct polarity, primary winding voltage will be in-phase with secondary winding voltage, with a phase angle difference of zero or close to that. A CT with reverse polarity would read the sum of the two primary and secondary voltages indicating a phase difference of approximately 180 degrees. MVCT performs this test in automated fashion and display the result as either Polarity correct or incorrect.

3.2.3 Excitation Test

IEEE defines the saturation as “the point where the tangent is at 45 degrees to the secondary exciting amperes”. Also known as “knee” point.

This test verifies that the CT is of correct accuracy rating, has no shorted turns in the CT and no short circuits are present in the primary or secondary windings of the CT under test.

A typical excitation curve for C class current transformer is shown in figure below.



An AC voltage is applied to the secondary winding of the CT. The voltage applied to the secondary winding of the CT is increased slowly automatically by the test set. Voltage and current readings for the secondary winding of CT are stored in the internal memory. At 300V AC the MVCT will switch to DC voltage to finish saturating the CT. Test set automatically convert the DC voltage readings, generate an AC excitation curve and determines the “Knee” point as per selected standard by observing a small voltage increase causing a large increase in current. The excitation curve around the points where

current jumps up for a small increase of voltage; is very important for comparison of curves with published curves or similar CT curves.

The MVCT plots the saturation curve on the display screen. Once a knee point is determined by the test set, it will also display the corresponding saturation voltage and saturation current on the display screen. Multiple CT saturation curves can be plotted on the same screen either for multi taps or for comparison of similar type CT's. The excitation test results should be compared with published manufacturer's data or previous recordings to determine any deviations from previously obtained curves.

The unit automatically demagnetizes the CT after performing the saturation test by slowing ramping down the secondary voltage all the way back to Zero. It is advisable to demagnetize the CT before performing any test that requires accurate measurements. Please refer to the section of CT Demagnetization for details.

3.2.4 Insulation Resistance Test

The insulation between the windings and winding to ground should be checked while performing a comprehensive CT test. The test set has inbuilt 1kV DC insulation tester that is used for measurement of insulation resistance.

The following three tests are recommended by the ANSI standard.

- Primary winding of the CT to Ground.
- Primary winding of the CT to the secondary winding of the CT
- Secondary winding of the CT to Ground

These three tests are performed to determine the condition of the insulation of the CT under test.

The DC test voltage is automatically ramped up slowly and the insulation reading in (M) ohms is displayed on the LCD display screen in digital format. The measured values should be compared with similar readings obtained previously and a large deviation should call for further investigation. Any reading in M ohms is considered to be a good insulation. The minimum insulation resistance that is accepted is 1 M ohms. More than a number, it's the trending of insulation test results that gives the true condition of CT insulation.

Insulation readings are greatly affected by the temperature. Should a reading be compared to previously taken readings, proper correction factors need to be applied, if taken under different temperature conditions before drawing any conclusion. Insulation resistance readings should remain fairly constant

over a period of time. A sharp dip in trending of insulation resistance values, point towards insulation degradation and further investigation is warranted to diagnose the problem.

3.2.5 Burden Test

Burden can be defined as the total impedance in ohms on the CT output terminals. Each CT has a secondary burden when connected in a relay or metering circuit. The total burden is a combination of impedance offered by watt-hour meter coils, relay current coils, contact resistance, terminal blocks, wire resistance and test switches used in the secondary loop.

Burden test is performed to verify that CT under test is capable of supplying a known current into a known burden while maintaining its stated accuracy. A burden test is typically performed at full rated secondary current value. Burdens are typically expressed in VA.

CT's can be classified into two groups.

- 1) Metering CT's
- 2) Relaying CT's

Metering CT's are typically specified as

0.2 B 0.5

The last number specifies the Burden in ohms. For a CT with secondary current of 5 A the VA burden rating can be calculated as

$$VA = \text{Voltage} * \text{Current} = (\text{Current})^2 * \text{Burden} = (5)^2 * 0.5 = 12.5 \text{ VA}$$

Relaying CT's are typically specified as

10 C 400

The last number specifies the max. Secondary voltage at 20 times the rated secondary current without exceeding the 10 % ratio error. For a CT with secondary current rated at 5 A, 20 times rated current secondary current would give a burden of 4 ohms.

$$\text{Burden} = 400 / (20 * 5) = 4 \text{ ohms}$$

Burden in VA can be specified as

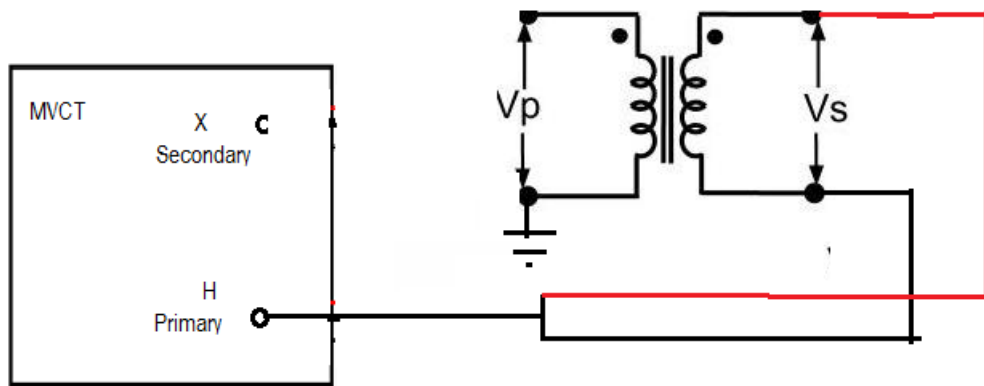
$$VA = \text{Voltage} * \text{Current} = (\text{Current})^2 * \text{Burden} = (5)^2 * 4 = 100 \text{ VA}$$

CT's are expected to provide the secondary output current based upon their accuracy class. If a CT is not properly sized based upon secondary loop burden, it may result in decrease in CT secondary current. Burden test is important to verify that CT is supplying current to a circuit with burden that does not exceed its burden rating.

A detailed description of how to perform a burden test with MVCT is given in the test procedure.

3.2.6 Secondary Winding Resistance

The transformer winding resistances can be measured by current voltage method. In this method of measurement of winding resistance, the MVCT injects test current into to the secondary LV winding and corresponding voltage drop across the winding is measured. By applying simple Ohm's law i.e. $R_x = V/I$, one can easily determine the value of resistance.



4.0 Powering System

4.1. Initial Start Up

1. If the unit was ordered with an integrated display, using the Ethernet cable supplied with the unit connect the STVI Ethernet Port on the MVCT unit to the Ethernet port on the lower front of the display module
2. Before connecting power to the unit, make sure the MVCT POWER ON/OFF Switch is in the OFF position (0). Plug the unit line cord into an appropriate power source and turn the POWER ON/OFF Switch to ON (I). As the MVCT unit goes through its power up sequence, in about a minute the display power up screen will appear, then the test configuration screen will appear.

5.0 User Interface

5.1 Integrated Display or Smart Touch View Interface

Depending on how the unit was ordered, the MVCT can be controlled using the integrated display, or a personal computer using PowerDB Lite software. Both of these methods of control will have the same user interface in the software and this will be outlined throughout.

For units being controlled with the integrated display or the STVI, the system will perform several self checks upon power up. Once these checks are complete the Introduction Screen will appear, see the following figure.



Figure 4 Initial Screen

Shortly afterward the screen will change to the instrument connection screen if the MVCT is being controlled with a laptop.

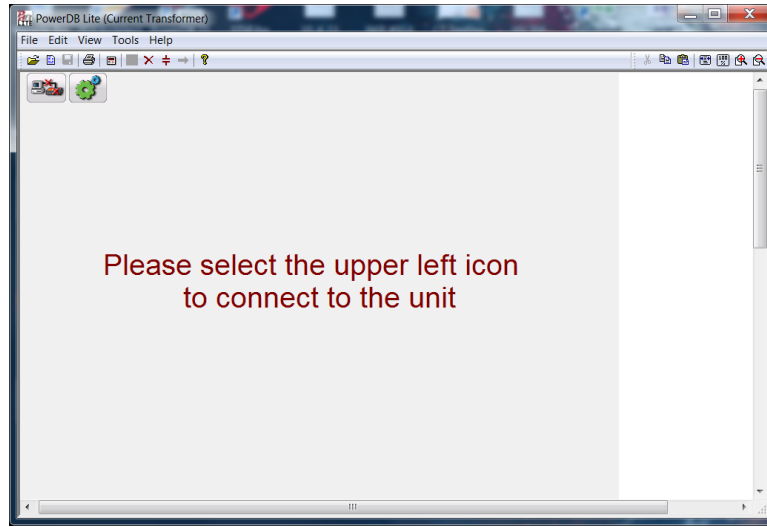


Figure 5 Instrument Connection Screen

The user should select the connection icon in the top left corner to connect to the MVCT. The user will then be brought to the “Home Screen”. If the MVCT has an integrated display, after powering up the MVCT, the user will be brought to the “Homes Screen” automatically.

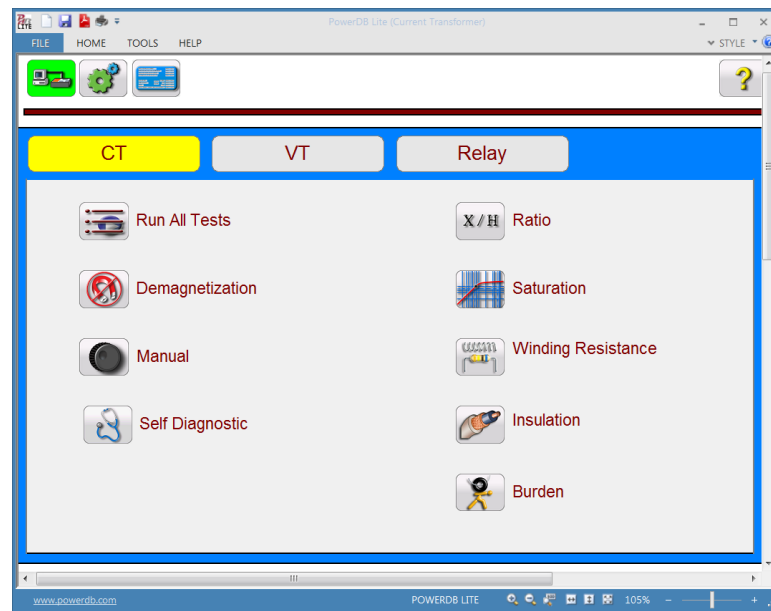


Figure 6 Boot Up Home Screen

5.2 Personal Computer Interface

For units being controlled with a personal computer, the user needs to install PowerDB Lite on the PC. The install disk is supplied with the unit. The user will then start the PowerDB Lite application. Once the application starts the Introduction Screen will appear, see the following figure.

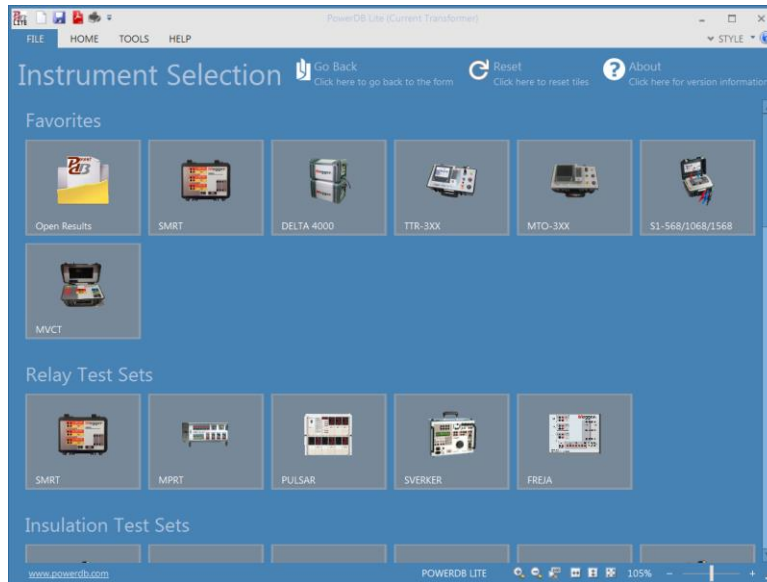


Figure 7 PowerDB Lite Initial Screen

From the PowerDB Lite Initial screen the user can control many of Megger's different testing instruments. After connecting the PC to the MVCT using the supplied Ethernet cable, to log onto the MVCT the user needs to select the MVCT icon. This will launch the Instrument Configuration dialog as seen below

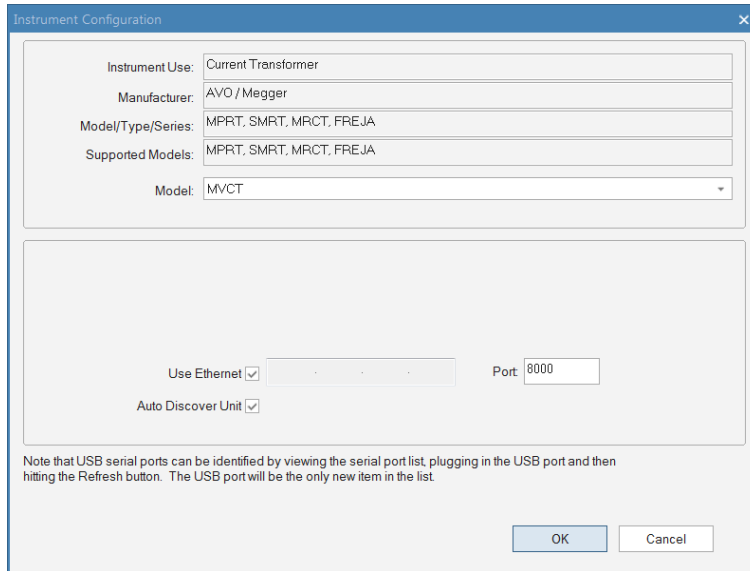


Figure 8 Instrument Configuration Dialog

If using the factory default settings, by clicking OK on the Instrument Configuration dialog will bring the user to the form selection dialog seen below.

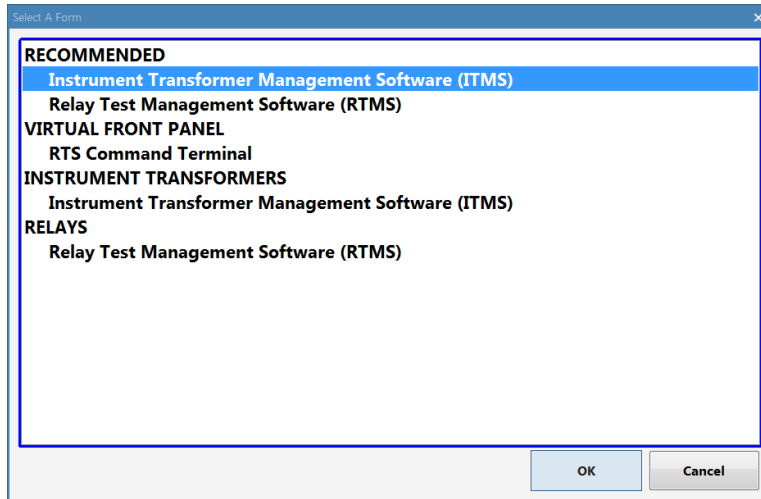


Figure 9 Form Selection Dialog

Here the user may select the appropriate form for the type of testing to be performed. For testing Instrument Transformers, the MVCT Form should be selected and then click OK on the dialog. This will bring the user to the instrument log on screen.

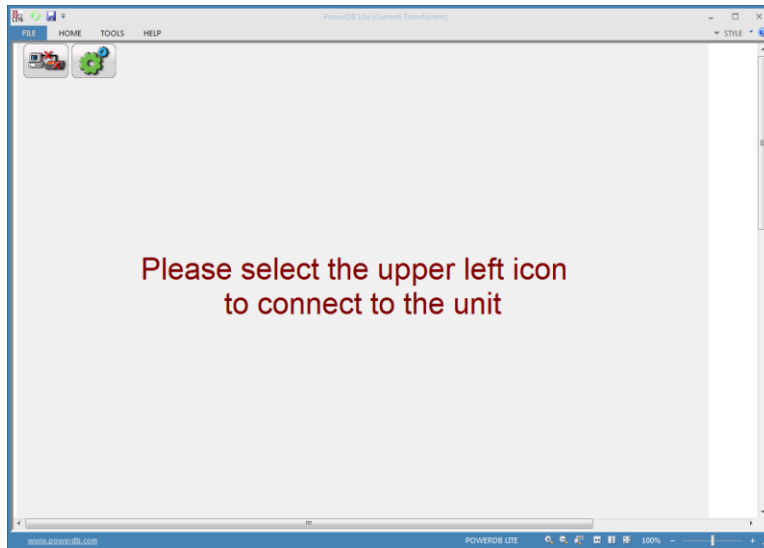


Figure 10 Instrument Logon Screen

Selecting the connection icon in the upper left corner of the window will launch the connection dialog shown below

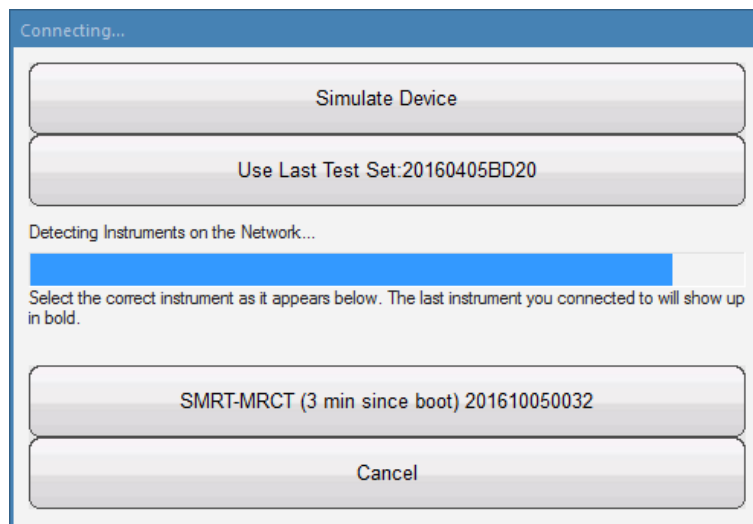


Figure 11 Connection Dialog

Once the PC has begun communicating with the MVCT, the device will appear in the dialog while showing the units serial number and the time since the unit was turned on. To complete the logon process select the unit. Once the logon process is complete, the user will be brought back to the Home Screen in the PowerDB Lite software.

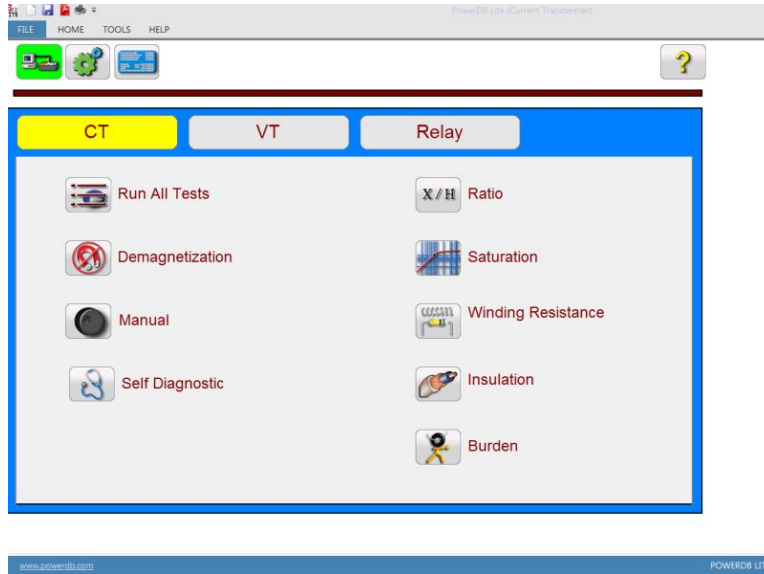


Figure 12 PowerDB Lite Home Screen

5.3 Software Interface

Whether the MVCT is being controlled with an integrated display, an STVI, or a personal computer the software has the same user interface. From this Home screen the user can navigate to the desired test screen. All individual test screens and settings for the unit can also be accessed from this screen. By pressing the navigation buttons on this screen, one can select the desired operation. Following are the user selectable operations.



Device Connection



Device Settings



Name Plate Information



User Help

CT CT Testing Selection

VT VT Testing Selection

Relay Relay Testing Selection

The following operations are available when the MVCT is in CT testing mode



Run All Test s



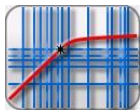
Manual Test



Demagnetization



“Self Diagnostic”



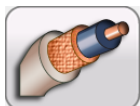
Saturation Test



Ratio Test



Winding Resistance Test



Insulation Test



Burden Test

The following operations are available when the MVCT is in Basic VT testing mode



Run All Tests



Demagnetization



“Self Diagnostic”

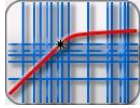


VT Ratio Test



VT Secondary Winding Resistance Test

Additional operations available when the MRCT is in Advanced VT testing mode



VT Saturation Test



VT Secondary Short Circuit Impedance Test

The following navigation buttons will appear in the home screen after a test has been completed and test data is available



View Test Report



Delete Test Data



File Manager

Refer to each menu item below for detailed description

5.4 Testing Mode


Depending upon how the MVCT was ordered, it has the capability of different modes of testing. By selecting the desired mode of testing, the MVCT can be placed in either CT Testing, VT Testing, or Relay testing mode of operation. The mode is selected by choosing the CT, VT, or Relay button at the top of the Home Screen. The active mode of operation is indicated by button being highlighted in yellow.

5.4.1 CT Testing Mode – Menu Items

Menu items are considered either system wide menu items or menu items that are available only within a specific mode of testing. Below are all the menu items available when the MVCT is set up for test CT's

5.4.1.1 Device Connections



Selection of  Device Connection button will initialize the connection to the MVCT

5.4.1.2 Device Settings



Selection of  Device Settings, brings the user the following screen.

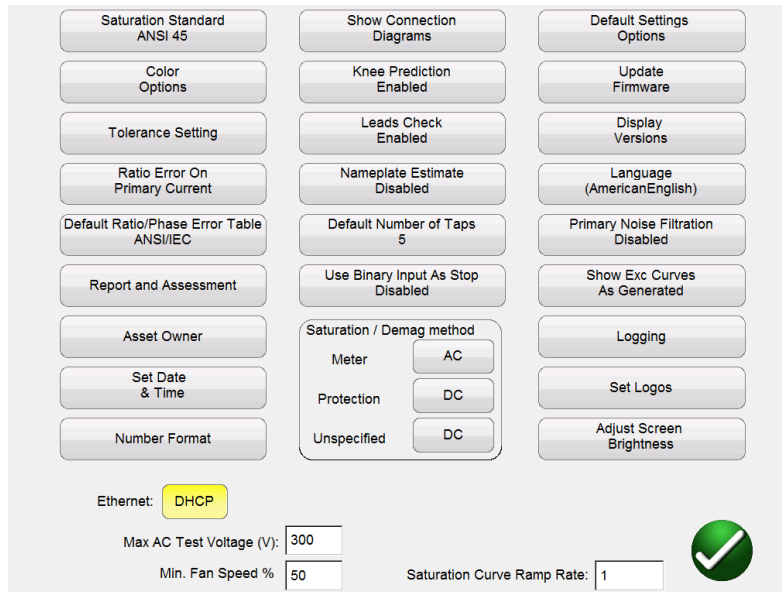


Figure 13 Device Settings – CT Testing

Within this screen all device settings are visible. However, only the settings that apply to the current mode of testing will be accessible. By selecting the appropriate button, the user can:

- **Saturation Standard:** Select between ANSI 45, ANSI 30, IEC 60044-1, IEC6044-6, or IEC61869
- **Color Options:** Select the desired colors for Background color, Grid color, Label color, Knee Marker color, and Saturation traces
- **Tolerance Settings:** Displays the ratio and phase error limits specified by either ANSI or IEC
- **Ratio Error on Primary/Secondary Current:** Allows user to select whether the ratio error is displayed on Primary Current (101:5) or displayed on Secondary Current (100:4.99)
- **Default Ratio/Phase Error Table:** Allows user to set the default ratio/phase error table that will be calculated for a CT. The button will toggle between ANSI/IEC table which will give the error for 1,5,10,20,50,100, 120, and 200% of primary current or the IS table which will give the error for 20,40, and 80% of primary current
- **Report and Assessment:** Allows the user to customize the report. He can select whether or not to display the ratio and phase error tables, the parallelograms, and whether or not to include an assessment. Several CT parameters will be evaluated. Both IEC and ASNI define different parameters for the different classes of CT. Thus the parameters assessed will vary depending upon the class of CT selected. Please note for this functionality to work, it must first be enabled, the CTs nameplate information must be completed, and then the Ct must be fully tested including saturation/excitation, ratio, phase, and winding resistance. Once the test is complete, the CT values will be assessed in the 3rd page of the report and the CT will be given a Pass/Fail assessment.

- **Asset Owner** Sets the asset owner in the report
- **Set Date Time** Change the time and date stored in the MVCT. This is only available in MVCT with integrated display or if they are controlled with an STVI
- **Number Format** Select between U.S. and International number formatting. This is only available in MVCT with integrated display or if they are controlled with an STVI
- **Show Connection Diagrams:** Allows user to turn off the functionality showing connection diagrams before each test. This is not recommended because of safety concerns.
- **Knee Prediction Enabled/Disabled:** Allows the user to enable and disable the knee point prediction algorithms. If the user enters the nameplate information, the MVCT will use this information to predict the knee point of the CT which can reduce testing time.
- **Lead Check Enable/Disable** Allows the user to enable and disable the lead checking algorithms. If enabled the MVCT will check connections prior to a test and monitor voltages and currents during the test. Anytime an unexpected value is detected the user will be warned to check the connections.
- **Nameplate Estimate Enable/Disable** Allows the user to enable and disable the nameplate estimation algorithms. If enabled the MVCT will estimate several nameplate values of the CT including ratio, VA rating, and accuracy class. For this functionality to work properly it must be enabled and the several tests must be performed on the CT from the Run All test screen. For accurate estimates data is needed from the saturation/excitation test, ratio & phase test, as well as the winding resistance test.
- **Default Number of Taps** Allows user to set the default number of taps on a CT. For example, if user only tests 2 tap/single ratio CTs then he can set the default number of taps to 2. Then whenever test screens appear they will always default to 2 taps instead of 5
- **Use Binary Input as Stop** Enables and disables the algorithms that monitor the binary IO ports and shuts down unit
- **Saturation / Demag Method:** The MVCT uses both AS and DC voltage for testing saturation point and knee points of CT. The MVCT has the ability to output up to 300V AC. This functionality allows the user to select the method which the MVCT uses for both saturating and/or demagnetizing a CT. Most metering class CT has a knee point less than 100V, so the user could set the method to use only AC on metering class CT. On the other hand, protection class CT may need much more voltage to saturate than 300V so it would be best to set protection class CT to use the DC method. Then for CT of unspecified type the user can select either AC or DC depending upon the voltage level required to saturate the CT. By setting the default of unspecified type to DC ensures that the CT will be tested correctly whether the knee point is above or below 300V

- **Default Settings Options:** Save changes made to defaults, restore defaults, or restore factory defaults
- **Upgrade Firmware:** Upgrade firmware for the MVCT or the STVI
- **Display Versions:** View all Software and hardware versions of the device.
- **Languages:** Select between American English, International English, Spanish, French, and German, Turkish
- **Primary Noise Filtration Enable/Disable** Allows the user to enable and disable a Primary Noise Filtration algorithm. This algorithm filters noise on the fundamental frequencies during the ratio measurement. This functionality should only be used in high voltage noisy environments where the measurement is being affected by induced voltage.
- **Show Excitation Curves as Generated** Toggles between modes that Shows Excitation Tests as Generated “ and “Quick Test Mode”. Shows Excitation Tests is the default mode but the Quick Test mode will perform 3 Tests (Excitation, Ratio, and Winding Resistance) in a significantly reduced test time. In Quick Test mode only a progress bar will be displayed during tests and results will be shown after all tests are complete in the report.
- **Logging:** Enable logging, clear all log files, or copy log files to USB. . This is only available in MVCT with integrated display or if they are controlled with an STVI
- **Adjust Screen Brightness:** Change the screen brightness using the manual control knob. . This is only available in MVCT with integrated display or if they are controlled with an STVI
- **Set Logos:** Allows user to set the logo to be used in the report. The file should be in ,bmp format and placed into the root directory of a usb stick. Then insert the USB stick into the USB port of the MVCT and hit the Set Logos button. This will copy and store the file and the logo will be included on top of the report in the future
- **Ethernet:** Enable and disable DHCP
- **Max Test Voltage:** Set the maximum voltage the MVCT will output during a saturation test
- **Saturation Curve Ramp Rate:** Allows user to speed up and slow down the rate at which the voltage is increased during the saturation test. The default is “1” which sets the speed to normal. By entering a number less than 1, the ramp rate will be decreased. For example entering “0.4” will reduce the normal voltage increment by 60%. This feature can be very useful when a CT saturates very quickly with minimal voltage increases
 - ❖ Please note that certain device settings will only be available for manipulation if the user is running the PowerDB application on an STVI (Smart Touch View Interface) or on an MVCT with integrated display. These settings include: Number Format, Adjust Screen Brightness, Set Date & Time, and Logging. If the application is running on a standard PC or laptop then these settings are adjusted within the PC’s operating system such as Windows.

5.4.1.3 Nameplate Information



Selection of Name Plate Information, brings the user to the screen allowing the user to input nameplate information. This screen will vary depending upon whether the MVCT is set for CT Testing or VT Testing. If the user has selected to put multiple CTs into one report, each CT will have a designation at the top of the dialog. The active CT will be high-lighted in yellow and the user can input information about the CT by selecting the appropriate button or field:

Figure 14 Name Plate Data – CT Testing Mode

Nameplate page is used to fill out the Name plate data of CT under test.

- Number of CTs: If controlling MVCT with Megger STVI then up to 12 CT can be included within one report. If controlling MVCT with PowerDB installed on PC then up to 18 CT can be included in one report.
- Number of Taps: CTs with up to 6 taps can be tested
- CT Label: The user can change the label to any desired 2 characters. These characters will be assigned to the tap designations
- CT Name: The user can select up to 6 characters. These 6 characters will be combined with the 2 CT Label characters to generate the CT name. For example in a file containing 3 CT, the user might choose PhA, PhB, and PhC for the name and X, Y, Z for the different labels. This would result in the 3 CT contained in the file being called PhA-X, PhB-Y, and PhC-Z
- Manufacturer: By touching the screen in this location a keyboard will appear that will allow the user to enter the manufacturer of the CT.

- Serial No: Use the virtual keyboard to fill CT serial no. from the nameplate of the CT under test.
- Asset ID: This is a user defined field.
- Phase: Can be used to identify the phase that the CT is located on
- Metering or Relaying: Select the type of CT. Selection of the type of CT affects the performance of the excitation test. Typically a metering class CT will saturate and thus have a knee point of less than 30V. So in order to gather enough data points to calculate the knee point, if the type of CT is set to “Metering” the MVCT will increment the voltage during the excitation by $\frac{1}{2}$ V increments. Conversely a relaying/protection class CT will saturate at much higher voltage levels. So if the type of CT is set to “Relaying” the MVCT will increase voltage increment with each subsequent step until the knee point is reached. This allows the MVCT to reduce the number of data points and thus the testing time of relaying class CT. Please note that if the type of CT is unknown then it is best to omit this selection. For if the type of CT is unknown then the MVCT will increment the voltage by $\frac{1}{2}$ V up to 30 V and then begin increasing the voltage increment until the knee point is reached.
- Saturation Standard: Select which standard will be used when testing the CT. The user can select between the 2 ANSI methods of ANSI 45 or ANSI 30, or several different IEC methods. The different IEC methods are IEC 60044-1; IEC 60044-6, and IEC 61869-2
- Accuracy Class: Use the drop down menu to select the CT accuracy class from available options such as

a) C10	h) T10
b) C20	i) T20
c) C50	j) T50
d) C100	k) T100
e) C200	l) T200
f) C400	m) T400
g) C800	n) T800
- VA: The VA rating of the CT can be obtained from the nameplate
- Burden The Burden rating of the CT can be obtained from the nameplate
- Buried CT in Delta Connection: The CT ratio is measured as ratio = V_x/V_h . However since the induced voltage measured through the H terminals of a Delta winding is $V = 2/3V_h$. Thus the measured ratio is $3/2$ higher than actual ratio. By checking this box when the CT under test is in a delta configuration, the MVCT will display the correct ratio by reducing measured ratio by $2/3$
- Simulated Primary Lead Swap Allows the user to simulate swapping polarity of the primary leads. This is for report purposes only
- In Service Tap: Can be used to identify which tap is in service. This value is for report purposes only
- Actual Burden (VA): Allows the user to identify the actual amount of burden connected to the CT. In the second page of the report, in the ratio and phase error tables, the performance of the CT is currently evaluated with 100%, 50%, 25%, and 12.5% of the rated burden. If a value is

entered in the Actual Burden field then the performance of the CT at the specified value will also be calculated.

- Ratio: For a multi- tap CT, different tap ratios can be obtained from nameplate and can be entered in nameplate screen. By entering these four ratios the MVCT will auto-determine all interior ratios and use these values when calculating ratio errors
- Copy From Button: If the user has selected to include multiple CT into one report, once data about one CT has been input, the copy from button can be used to copy identical information from one Ct to another
- User Descriptions and Values are used to fill out the optional testing information such as
 1. Technician name,
 2. Company information,
 3. Substation location,
 4. Position and phase of CT
 5. type of CT - Bar Type or Window Solid Core
 6. Other relevant testing data.

Note: All the information in Nameplate screen is optional. It is not required to perform a test on CT. The MVCT will attempt to estimate the nameplate values. However by inputting any data that is known a more precise estimate can be made for any missing data and a more complete report can be generated.

5.4.1.4 Home Screen



Selection of Home Button, the user will be brought to the home screen from which the user can navigate to any test.

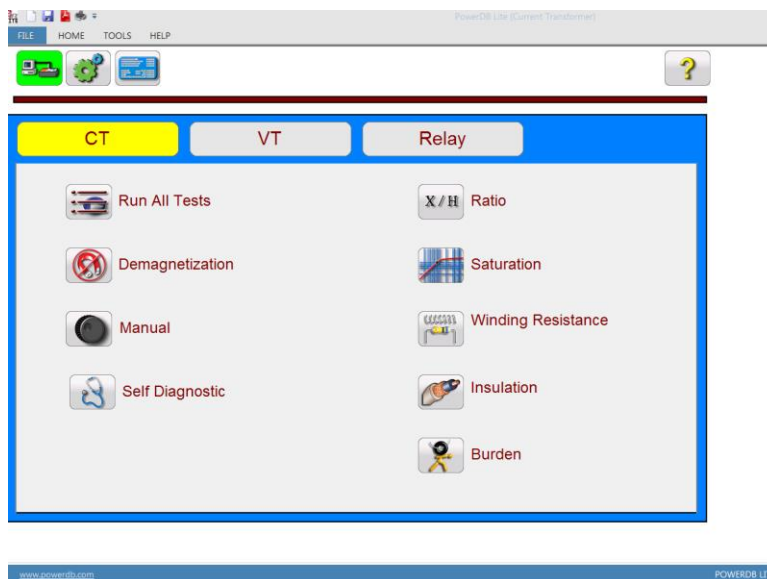


Figure 15 Home Screen CT Testing

5.4.1.5 Run All Tests



Selection of Run All Tests button will bring the user to the Test Configuration screen

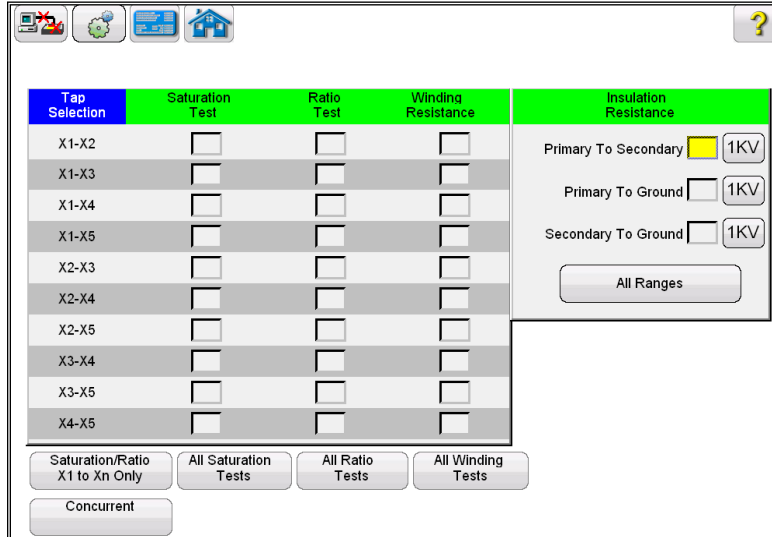
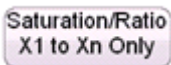
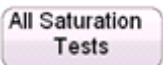


Figure 16 Run All Test Screen

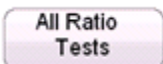
The user can easily configure a test plan for a current transformer by checking the box adjacent to the desired test of the desired tap. The various buttons at the bottom of the screen can also be used to easily configure a test:



Used to auto select Saturation and Ratio Test on all external taps. Uses nameplate "Number of Taps" to configure



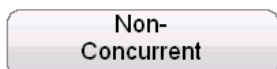
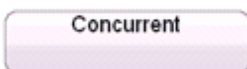
Used to auto select Saturation Test on all taps



Used to auto select Ratio Test on all taps



Used to auto select Winding Resistance Test on all taps



Used to toggle between Concurrent Testing of all taps and testing tap individually.



Button used to toggle insulation test between 1KV and

500V

5.4.1.6 Manual Test



Selection of the Manual Test Button, will bring the user to the following Manual Test Screen.

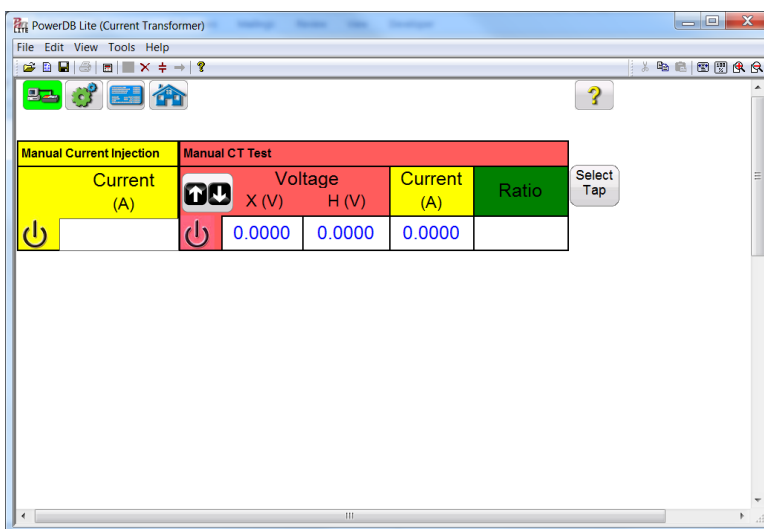
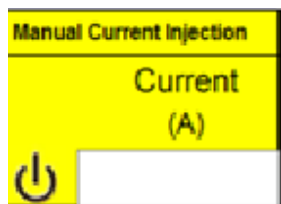



Figure 17 Manual Test Screen

Within the Manual Test Screen the user has the options of performing various operations from injecting current into a load to manually testing the ratio and saturation point of a CT.

Current Injection: If the MVCT has been ordered with the “Relay Testing” option then the Manual Current Injection screen will be available. To inject current into any load, the user must enter the desired current level into current box.



Then selecting the ON button  on the touch screen the MVCT will first display a connection diagram. Once the user verifies the connection, by selecting the blue play button the MVCT will output the specified current level

Ratio Testing; To manually test the ratio of a CT the user is required to first select which individual tap is desired



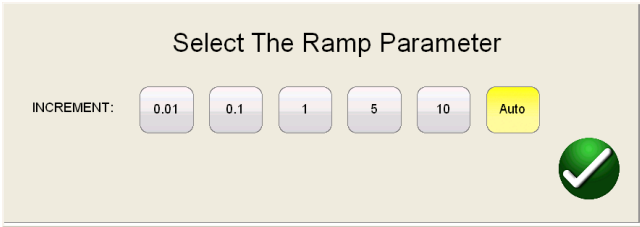
Hitting the select tap button will activate the tap selection dialog




After selection of the desired individual tap selection, the user may adjust the voltage increment selecting the Ramp adjustment button



This will activate the ramp parameter dialog allowing the user may select the amount of increment the voltage is either decreased or increased by turning the knob on the STVI or the up/down arrow keys on a laptop



After the desired tap selection is made and any adjustments made to the ramp parameter, the user must select the ON button.  to begin the test. At this time a connection diagram will be displayed. Once the user has verified proper connections, the test is continued by selecting the blue play button on the connection diagram.

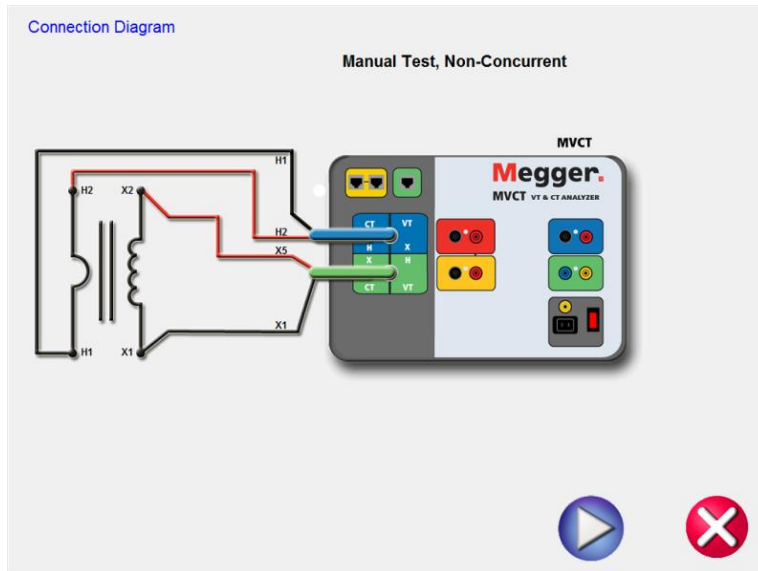


Figure 18 Manual Test Connection Diagram

After the MVCT has begun to inject voltage, the voltage and current readings will be displayed along with the calculated ratio. In order to ensure accurate results on the ratio, the voltage should be ramped to a level of at least 10% of the value of the knee point of the CT. The readings should also be allowed to stabilize.

Running Manual CT Test					
Manual Current Injection	Manual CT Test			X1-X2	
Current (A)	Voltage		Current (A)	Ratio	
	X (V)	H (V)			
	1.0000	0.0500	1.0000	100:5	

Up to 14 points can be saved

Manual Saturation Test: To manually run a Saturation test on a CT the user is required to first select which individual tap is desired



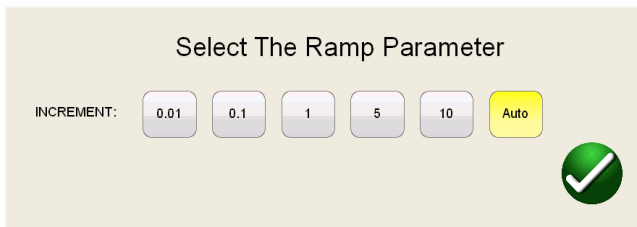
Hitting the select tap button will activate the tap selection dialog




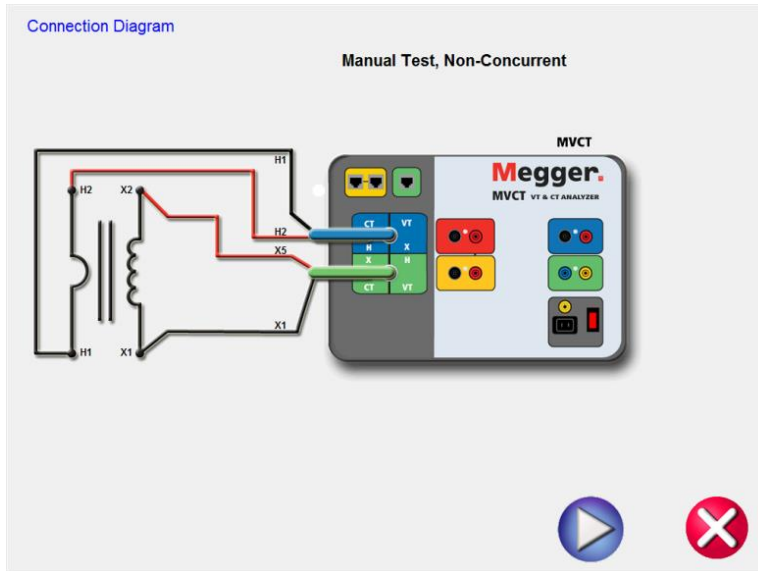
After selection of the desired individual tap selection, the user may adjust the voltage increment selecting the Ramp adjustment button



This will activate the ramp parameter dialog allowing the user may select the amount of increment the voltage is either decreased or increased by turning the knob on the STVI or the up/down arrow keys on a laptop



After the desired tap selection is made and any adjustments made to the ramp parameter, the user must select the ON button.  to begin the test. At this time a connection diagram will be displayed. Once the user has verified proper connections, the test is continued by selecting the blue play button on the connection diagram.



After the MVCT has begun to inject voltage, the voltage and current readings will be displayed along with the calculated ratio. The user must ramp the voltage using either the round control knob on the STVI or the up/down arrow keys on a laptop. Once the user has reached a desired voltage, a point may be saved by selecting the image of a floppy disk.

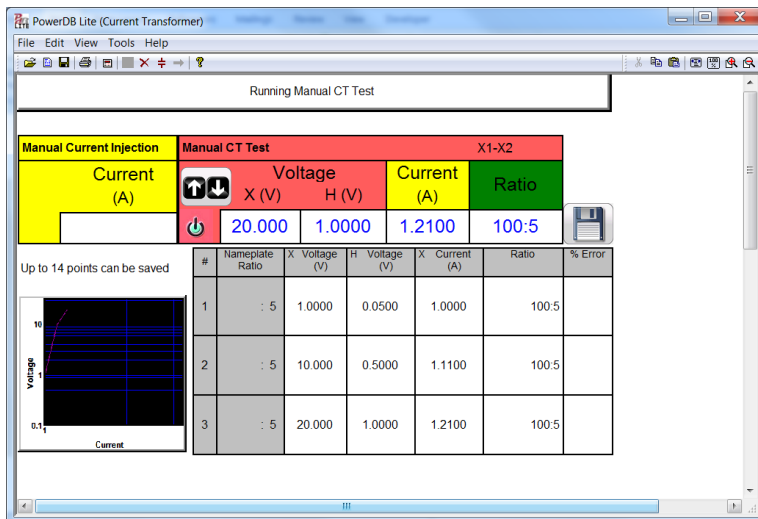


Figure 19 Manual Test Example

Once the user has generated at least two data points, the MVCT will begin to graph the saturation curve. The user can then continue to ramp the voltage while taking data points until the CT reaches saturation. The user may store up to 14 data points.

5.4.1.7 Demagnetization



Selection of Demagnetization, brings the user to the following connection diagram .

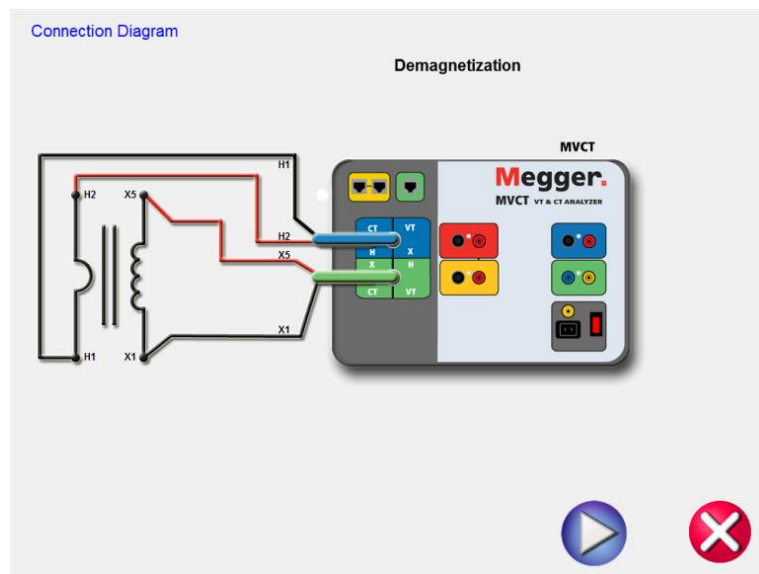


Figure 20 Demagnetization Connection Diagram

After confirming the connections are correct, continue with demagnetizing the CT by selecting the green CHECK. The red X will cancel the operation.

After selecting to continue the operation, the user will be advised that the CT is being demagnetized

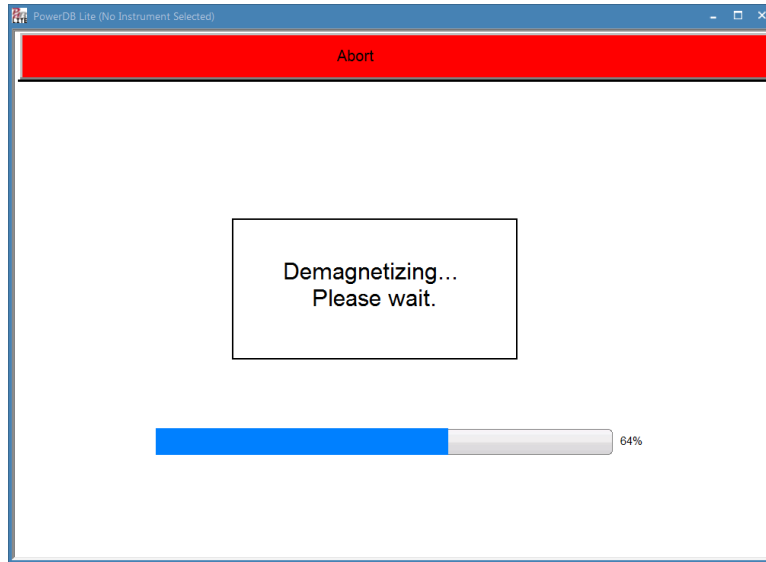


Figure 21 Demagnetization Process

Upon completion, the user will be returned to the Main Test Configure Screen and notified the demagnetization process is complete.

5.4.1.8 Self Test



Selection of the “Self Diagnostic” navigation button from the home screen will display a connection diagram

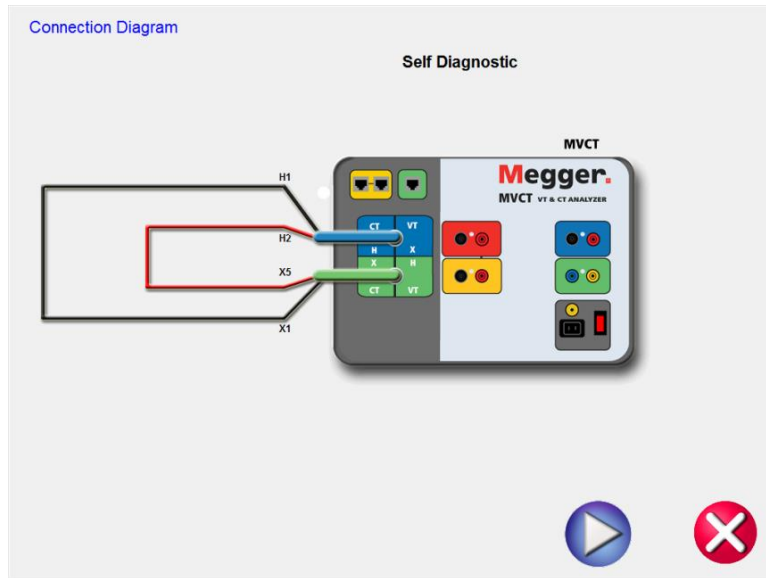


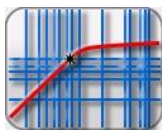
Figure 22 Self Test Connection Diagram

After the user has ensured the MVCT is connected properly as in the diagram, the self test is begun by selecting the blue play button



While the user can completely test a current transformer from the Run All Tests screen, individual tests may be accessed from the correlating buttons in the drop down list.

5.4.1.9 Saturation



Selection of Saturation Test button from the test configuration screen will bring the user to the following Saturation Test screen



Figure 23 Saturation Test Screen

Within this screen the user can select between Concurrent and Non concurrent Testing



When Concurrent Mode of testing is selected, the user is required to select how many taps is desired to test simultaneously



However if the Non Concurrent Mode of testing is selected, the user is required to select which individual tap is desired



Hitting the select tap button will activate the tap selection dialog



After either selecting the number of taps or the individual tap selection, the saturation test is begun by selecting the blue play button.



5.4.1.10 Ratio




Selection of  Ratio Test button from the test configuration screen will bring the user to the following Ratio Test screen



Figure 24 Ratio Test Screen

Within this screen the user can select between Concurrent and Non concurrent Testing



When Concurrent Mode of testing is selected, the user is required to select how many taps is desired to test simultaneously



However if the Non Concurrent Mode of testing is selected, the user is required to select which individual tap is desired



Hitting the select tap button will activate the tap selection dialog



After either selecting the number of taps or the individual tap selection, the ratio test is begun by selecting the blue play button.



5.4.1.11 Winding Resistance



Selection of Winding Resistance Test button from the test configuration screen will bring the user to the following Winding Resistance Test screen.

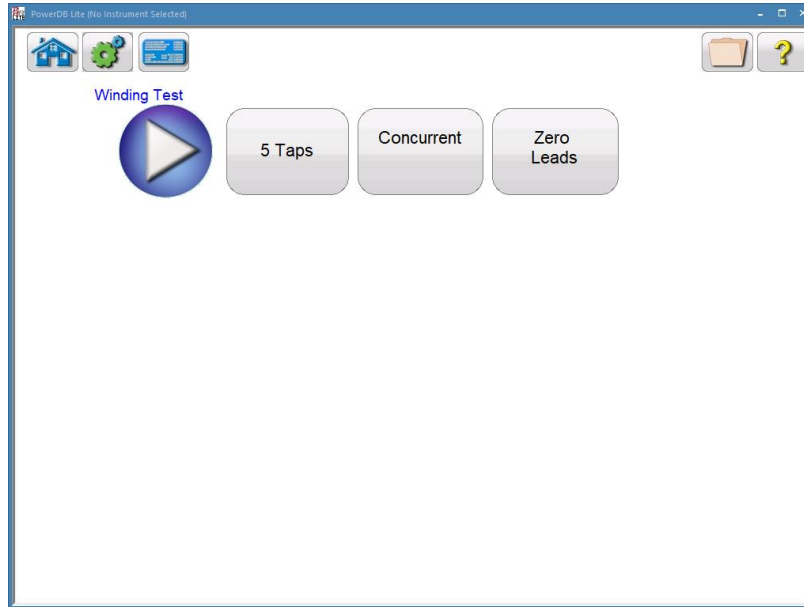
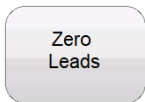
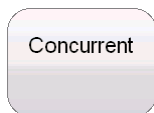


Figure 25 Winding Resistance Test Screen



Use the Zero Leads button to zero out the leads from the measurement. This will ensure no resistance from the leads is included in the resistance measurement and improve the accuracy of the measurement.

Within this screen the user can select between Concurrent and Non concurrent Testing



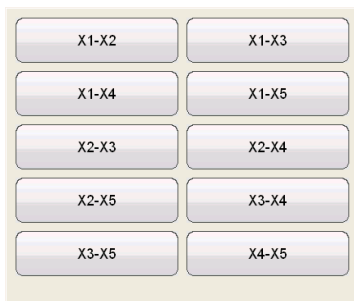
When Concurrent Mode of testing is selected, the user is required to select how many taps is desired to test simultaneously



However if the Non Concurrent Mode of testing is selected, the user is required to select which individual tap is desired



Hitting the select tap button will activate the tap selection dialog



After either selecting the number of taps or the individual tap selection, the Winding Resistance test is begun by selecting the blue play button.



5.4.1.12 Insulation Test



Selection of Insulation Test button from the test configuration screen will bring the user to the following Insulation Test screen

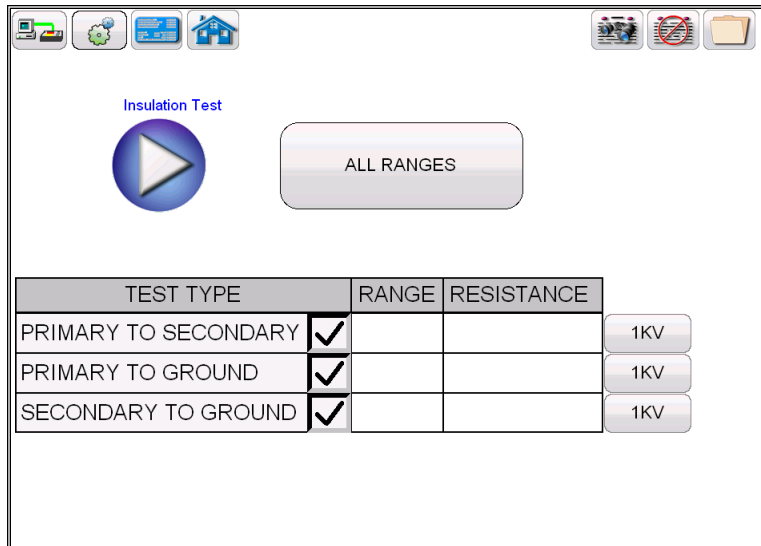


Figure 26 Insulation Resistance Test Screen

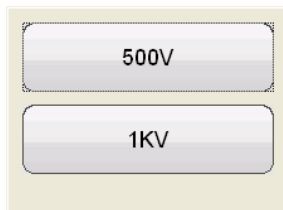
Within the Insulation test screen, the user may select the desired test level of either 500V or 1 KV by using the Voltage selection button



Each test may be set to a different test voltage. The user can also set the same test voltage to all tests by selecting the all Ranges Button



And then selecting the desired voltage



After selecting the desired test voltage, the user may select which test is desired by checking the correlating check box.

Then after selecting both the desired test voltage and the desired test, the insulation testing is begun by selecting the blue play button.



5.4.1.13 Burden



Selection of Burden Test button from the test configuration screen will bring the user to the following Burden Test screen

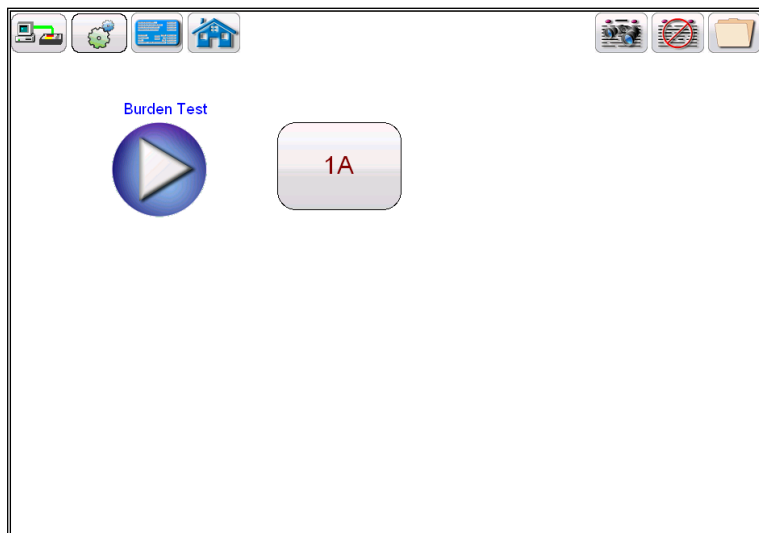


Figure 27 Burden Test Screen

Within the Burden test screen, the user may select the appropriate test current of either 1 Amp or 5 Amp based upon secondary current rating of the CT under test



5A

After either selecting the appropriate test current, the burden test is begun by selecting the blue play button.



5.4.1.14 View Report



If a test has been run and data is present the View Test Report button will be available. Selection of this button will generate a report of all test data for the active CTs. Data in the report regarding customer information may be entered here

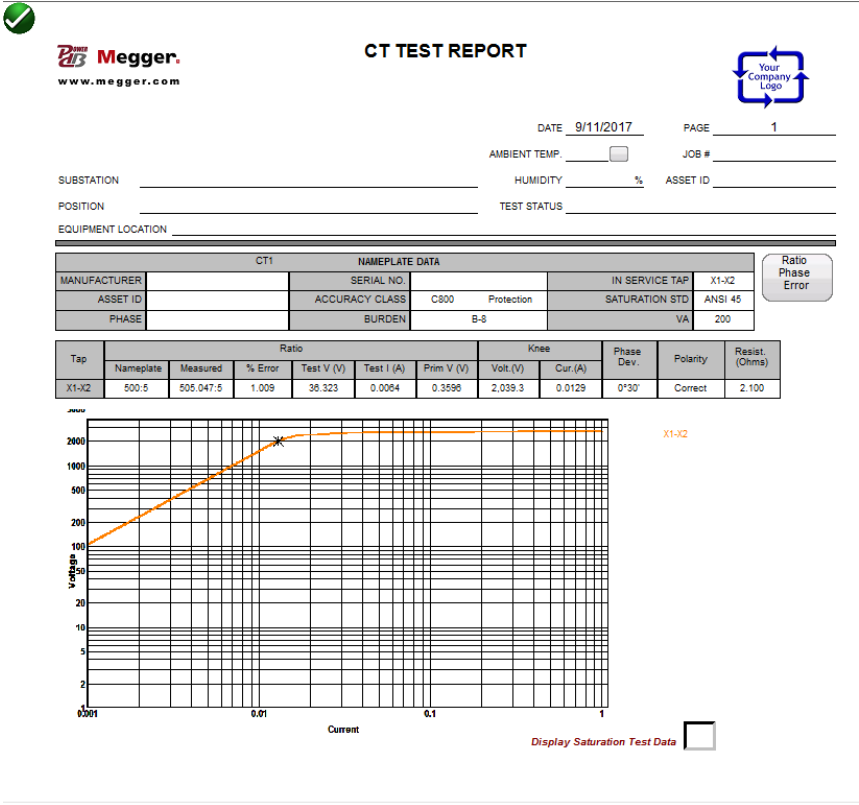
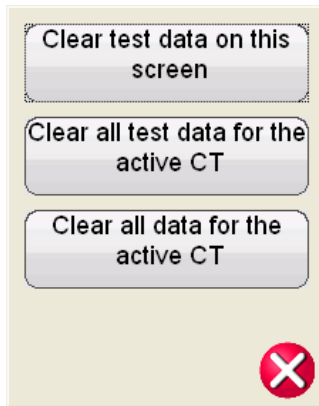


Figure 28 Sample CT Test Report

5.4.1.15 Delete Data



If a test has been ran and data is present; the Delete Test Data button will be available. Selection of this button activates the following dialog



This will allow the user three options of deleting data

- Clear test data on screen will only clear the data of the test screen currently active
- Clear all test data for active CT will the test data for the active CT but not delete the nameplate information that has been entered
- Clear all data for active Ct will delete all test data and nameplate information

5.4.1.16 Report Configuration

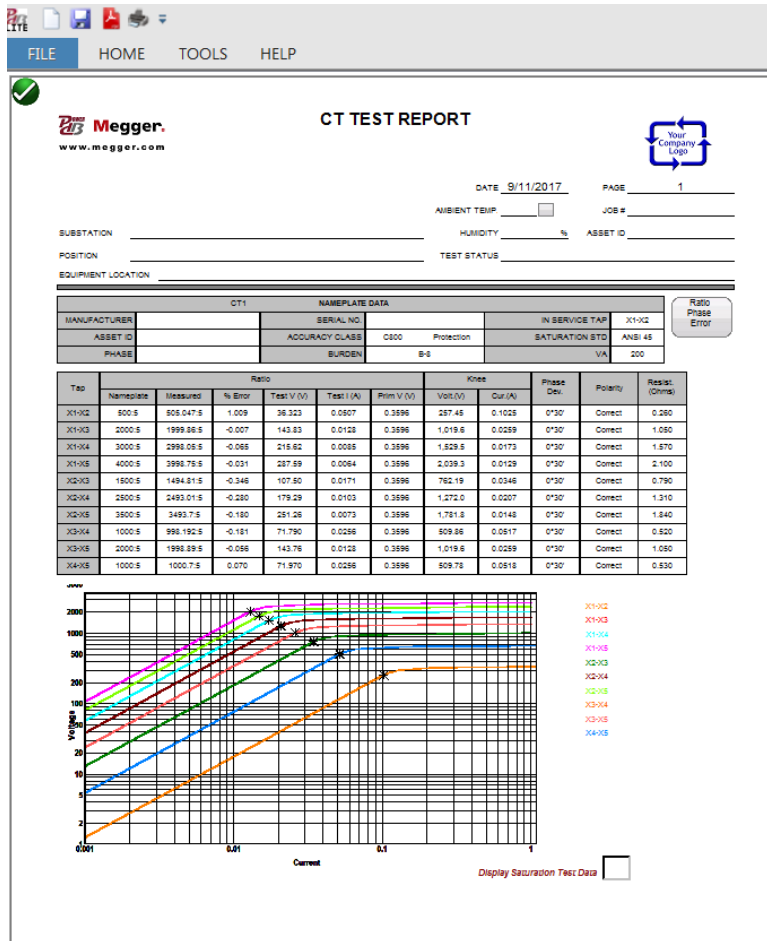


Figure 29 Sample Multi Tap Test Report

The MVCT will provide a concise one page report that will include all testing results including the data from the following tests: excitation; ratio; phase deviation; polarity; winding resistance; and insulation resistance. The MVCT report can also be configured to provide additional data including the ratio and phase errors at various percentages of primary current and at different levels of burden as seen below.

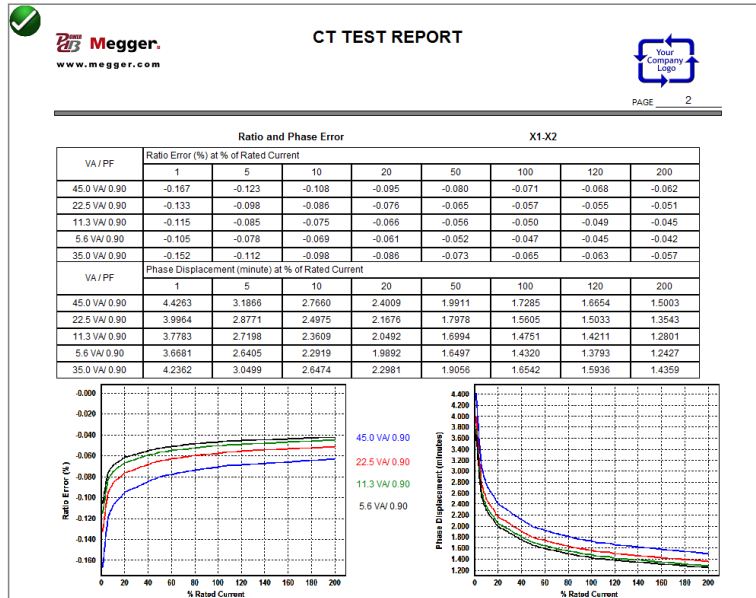
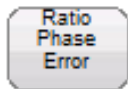


Figure 30 Ratio and Phase Error Tables

In device settings the user can configure the report to contain any of the following: Ratio Error Table, Ratio Error Graph, Phase Displacement Table, Phase Displacement Graph and assessment of the CT under test. If any of these have been included in the report, after testing the CT, the user can use the Ratio Phase Error Button to control the number of taps displayed.



Ratio & Phase Error Button


The “ Ratio & Phase Error “ button will be visible within the report only if the user selected them in device settings, has entered the correct nameplate information and has also executed the required tests. First the user must enter the following CT Name Plate information:

- CT Type either Metering or Relaying
- Accuracy Class
- Burden and/or VA
- Ratio

Then if the user executes the required tests of the CT

- Saturation/Excitation
- Ratio
- Winding Resistance

Then the “ Ratio & Phase Error “ button will be visible within the report. This button will give the user additional control over what is contained within the report. If the user included any of the following in the report: Ratio Error Table, Ratio Error Graph, Phase Displacement Table, Phase Displacement Graph and the CT under test has more than 1 ratio, then the user can specify to include additional taps in the report

Select the following contents to be included in report: 

Ratio Error Table

Ratio Error Graph

Phase Displacement Table

Phase Displacement Graph

On Taps:

<input checked="" type="checkbox"/> S1-S2	<input type="checkbox"/> S1-S3	<input type="checkbox"/> S1-S4
<input checked="" type="checkbox"/> S1-S5	<input type="checkbox"/> S2-S3	<input type="checkbox"/> S2-S4
<input type="checkbox"/> S2-S5	<input type="checkbox"/> S3-S4	<input type="checkbox"/> S3-S5
<input type="checkbox"/> S4-S5		

Figure 31 Report Tap Configuration Dialog

As mentioned previously, in device settings the user can configure the report to contain the ratio and phase error tables and graphs, ANSI accuracy parallelograms, as well as a CT Assessment. But within the report itself the user can configure any combination of taps or all the taps. Within the Tap Configuration dialog, place a check mark in the box beside the desired data and the desired tap and data for that tap will be included in the report. Please note that the nameplate data can be entered at any time either before the test or after the test has been completed and saved and the “ Ratio & Phase Error “ button will become available within the report. Also please note that by default, only the external tap is initially included.

5.4.1.17 Excitation Curve Data

Data points for the excitation curve graphs are saved within each test file. Up to 30 data points for each excitation curve can be displayed within the report by selecting the “Display Saturation Test Data” check box within the report.

Additional data points can be viewed from the Saturation/Excitation Test Screen.

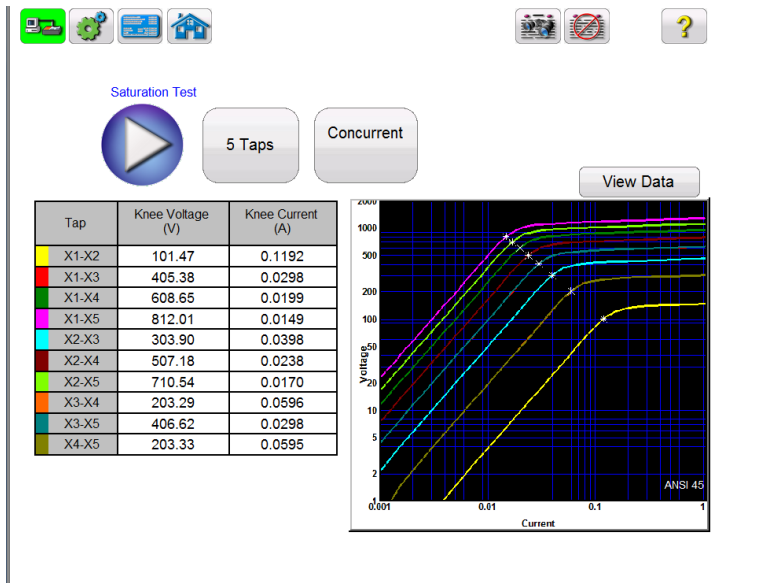


Figure 32 Excitation Curve Data

Within the test screen, if the test has completed and data is available, the user can access this data by selecting the “ View Data” button.



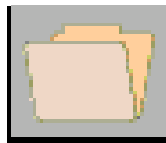
Selection of the view data button will launch a data viewer that will allow the user to view, or copy the data for inclusion into a separate file that can be included with the standard CT Test Report.

X1-X2		X1-X3		X1-X4		X1-X5		X2-X3	
I(A)	V(V)	I(A)	V(V)	I(A)	V(V)	I(A)	V(V)	I(A)	V(V)
0.0016	0.2534	0.0004	0.9992	0.0003	1.4995	0.0002	1.9993	0.0005	0.7458
0.0055	2.0190	0.0014	7.9973	0.0009	11.996	0.0007	15.995	0.0019	5.9783
0.0079	3.4831	0.0020	13.792	0.0013	20.691	0.0010	27.581	0.0027	10.309
0.0135	7.2217	0.0034	28.600	0.0023	42.900	0.0017	57.204	0.0045	21.378
0.0206	12.484	0.0052	49.435	0.0035	74.162	0.0026	98.886	0.0070	36.951
0.0293	19.169	0.0074	75.918	0.0049	113.89	0.0037	151.85	0.0099	56.749
0.0372	25.757	0.0094	101.99	0.0063	153.00	0.0047	203.86	0.0126	76.233
0.0435	31.747	0.0110	125.73	0.0073	188.62	0.0055	251.19	0.0147	93.983
0.0562	43.621	0.0142	172.72	0.0095	258.86	0.0071	345.49	0.0190	129.10
0.0705	57.983	0.0178	229.15	0.0119	344.22	0.0089	459.23	0.0239	171.17
0.0816	68.959	0.0206	272.64	0.0137	409.44	0.0103	546.21	0.0276	203.68
0.0959	83.178	0.0242	329.00	0.0161	493.97	0.0121	658.91	0.0324	245.82
0.1022	89.749	0.0258	355.03	0.0172	533.01	0.0129	710.94	0.0346	265.28
0.1046	91.966	0.0264	363.77	0.0176	546.10	0.0132	728.44	0.0354	271.80
0.1069	94.133	0.0270	372.37	0.0180	558.98	0.0135	745.63	0.0362	278.24
0.1101	96.314	0.0278	381.07	0.0185	572.01	0.0139	762.96	0.0372	284.76
0.1125	98.528	0.0284	389.73	0.0189	585.08	0.0142	780.40	0.0381	291.20
0.1149	100.72	0.0290	398.41	0.0193	598.15	0.0145	797.84	0.0389	297.69
0.1180	103.01	0.0298	407.54	0.0199	611.78	0.0149	815.99	0.0399	304.53
0.1236	107.35	0.0312	424.68	0.0208	637.50	0.0156	850.33	0.0418	317.33
0.1450	119.12	0.0366	471.39	0.0244	707.53	0.0183	943.64	0.0490	352.27
0.2012	132.16	0.0509	522.87	0.0339	784.89	0.0254	1046.8	0.0681	390.71
0.8784	148.20	0.2220	586.49	0.1479	880.20	0.1109	1173.8	0.2970	438.29

Figure 33 View Excitation Data Points

5.4.1.18 File Operations

Files operations will vary depending upon whether the user is controlling the MVCT with a PowerDB installed on PC or the MVCT's integrated display. For units being controlled with the MVCT's integrated display, once a CT has been tested and a test file exists, the File Manager button will be available.



Selection of File Manager button, brings the user to the following tool bar

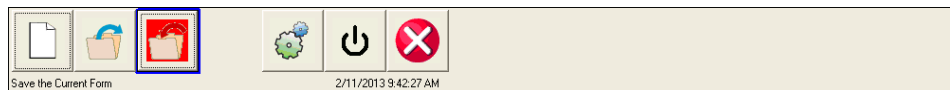


Figure 34 File Operation Tool Bar

The toolbar is used to Open File; Close File; or Cancel. Selecting either Open File or Close File will open the File Manager Dialog (see below)

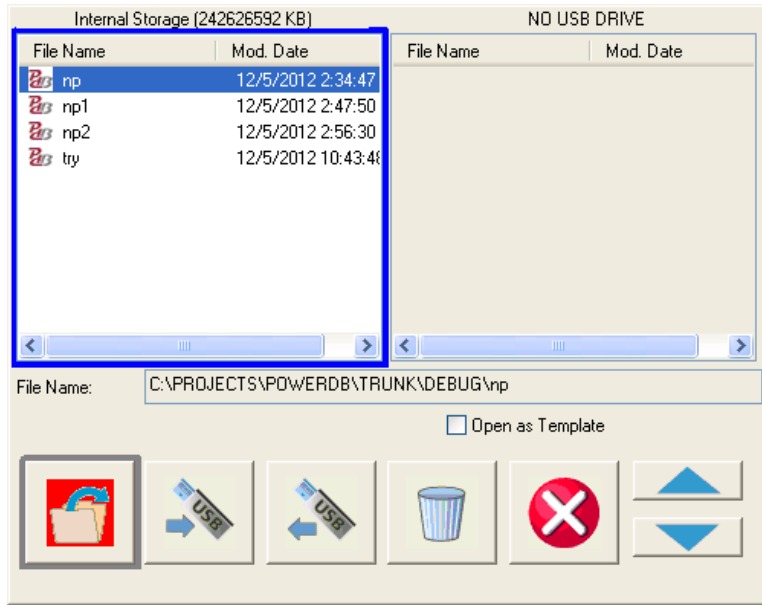


Figure 35 File Manager Screen

File manager screen is used to view and access the stored test results. All stored test results are displayed in alphabetical order along with date and time stampings.

Function buttons are used to recall, delete or transfer the test results. The function buttons are used to manage files as below:



Used to open file highlighted in the internal storage list



Used to save file named in edit box to system memory



Used to transfer file highlighted in the internal storage list to a USB stick



Used to transfer file highlighted in the USB drive list to internal system



Used to delete file highlighted in internal storage list



Cancels operation and closes dialog



Used to scroll file selection highlight up and down

If the MVCT is being controlled using PowerDb installed on a PC, then a different interface is available for file operations.

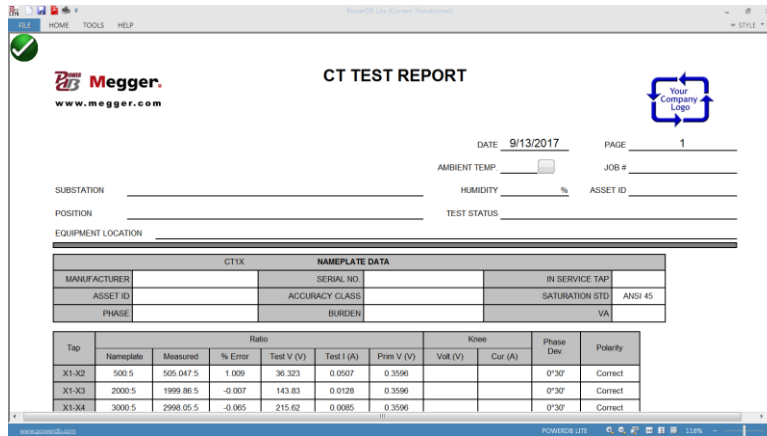


Figure 36 File Operations Using PC

Access to the file operations is gained through the FILE tab in the PowerDB window.

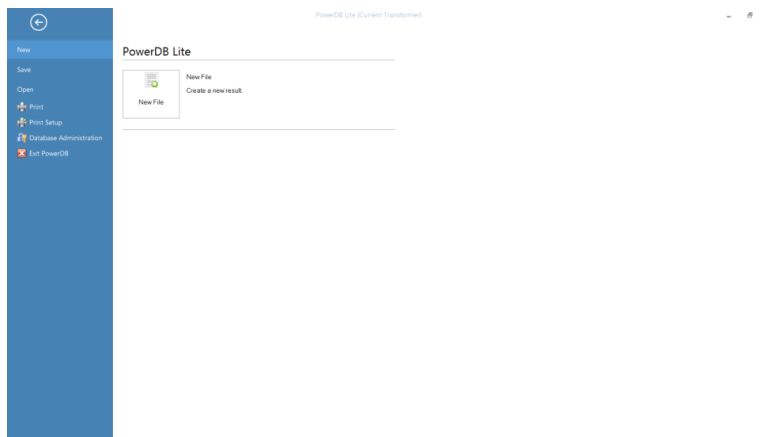


Figure 37 File Save Using PC

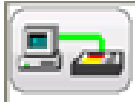
From here the user can create a New File, Save the current File, open an existing File, or print the existing file.

5.4.2 VT Testing Mode – Menu Items

Menu items are considered either system wide menu items or menu item that are available only within a specific mode of testing. Below are all the menu items available when the MVCT is set up for test VT's

5.4.2.1 Device Connections



Selection of  Device Connection button will initialize the connection to the MVCT

5.4.2.2 Device Settings



Selection of  Device Settings, brings the user the following screen.

Standard IEC	Show Connection Diagrams	Default Settings Options
Color Options	Knee Prediction Enabled	Update Firmware
Tolerance Setting	Leads Check Enabled	Display Versions
Ratio Error On Primary Current	Nameplate Estimate Disabled	Language (AmericanEnglish)
Default Ratio/Phase Error Table ANSI/IEC	Default Number of Taps	Primary Noise Filtration Disabled
Report and Assessment	Use Binary Input As Stop Enabled	Logging
Asset Owner		Set Logos
Set Date & Time		Adjust Screen Brightness
Number Format		

Ethernet: DHCP

Max AC Test Voltage (V):

Min. Fan Speed %

Saturation Curve Ramp Rate:

Figure 38 Device Settings – VT Testing

Within this screen all device settings are visible. However, only the ones that apply to the current mode of testing will be accessible. As on the unit, setting unavailable in VT testing mode will be grayed out.

Settings that are accessible will be in black. VT accessible buttons shown below in black and a description of what the user can change follows:

- **Standard:** Select between ANSI, and IEC
- **Color Options:** Set colors in excitation curves
- **Tolerance Settings:** Not Available
- **Ratio Error on Primary/Secondary Current:** Not Available
- **Default Ratio/Phase Error Table:** Not Available
- **Report and Assessment:** Allows the user to customize the report. He can select whether or not to display the ratio and phase error tables
- **Set Date Time** Change the time and date stored in the MVCT. This is only available in MVCT with integrated display or if they are controlled with an STVI
- **Number Format** Select between U.S. and International number formatting. This is only available in MVCT with integrated display or if they are controlled with an STVI
- **Show Connection Diagrams:** Allows user to turn off the functionality showing connection diagrams before each test. This is not recommended because of safety concerns.
- **Knee Prediction Enabled/Disabled:** Not Available
- **Lead Check Enable/Disable** Allows the user to enable and disable the lead checking algorithms. If enabled the MVCT will check connections prior to a test and monitor voltages and currents during the test. Anytime an unexpected value is detected the user will be warned to check the connections.
- **Nameplate Estimate Enable/Disable:** Not Available
- **Default Number of Taps:** Not Available
- **Use Binary Input as Stop:** Not Available
- **Default Settings Options:** Save changes made to defaults, restore defaults, or restore factory defaults
- **Upgrade Firmware:** Upgrade firmware for the MVCT or the STVI
- **Display Versions:** View all Software and hardware versions of the device.
- **Languages:** Select between American English, International English, Spanish, French, and German, Turkish
- **Primary Noise Filtration Enable/Disable** Allows the user to enable and disable the primary noise filtration algorithm. This should only be enabled in environments where induced voltage is effecting the testing results
- **Logging:** Enable logging, clear all log files, or copy log files to USB. . This is only available in MVCT with integrated display or if they are controlled with an STVI

- **Adjust Screen Brightness:** Change the screen brightness using the manual control knob. . This is only available in MVCT with integrated display or if they are controlled with an STVI
- **Set Logos:** Allows user to set the logo to be used in the report. The file should be in ,bmp format and placed into the root directory of a usb stick. Then insert the USB stick into the USB port of the MVCT and hit the Set Logos button. This will copy and store the file and the logo will be included on top of the report in the future
- **Ethernet:** Enable and disable DHCP
- **Max Test Voltage:** Set the maximum voltage the MVCT will output during any test
- **Saturation Curve Ramp Rate:**
 - ❖ Please note that certain device settings will only be available for manipulation if the user is running the PowerDB application on an STVI (Smart Touch View Interface) or on an MVCT with integrated display. These settings include: Number Format, Adjust Screen Brightness, Set Date & Time, and Logging. If the application is running on a standard PC or laptop then these settings are adjusted within the PC's operating system such as Windows.

5.4.2.3 Nameplate Information




Selection of  Name Plate Information, brings the user to the screen allowing the user to input nameplate information. This screen will vary depending upon whether the MVCT is set for CT Testing or VT Testing. The VT nameplate information screen below allows the user to input data about the VT under test.

Figure 39 Name Plate Data – VT Testing Mode

Nameplate page is used to fill out the Name plate data of VT under test.

- Number of VTs: Up to 18 VT can be included within one report
- Number of Windings: Currently VT are limited to one winding
- Number of Taps: Currently VT are limited to 2 taps
- VT Label
- VT Name
- Manufacturer: By touching the screen in this location a keyboard will appear that will allow the user to enter the manufacturer of the VT.
- Serial No: Use the virtual keyboard to fill VT serial no. from the nameplate of the VT under test.
- Asset ID: This is a user defined field.
- Phase: Can be used to identify the phase that the VT is located on
- Metering or Relaying: Select the type of VT. Depending upon the type of VT selected, the MVCT will populate the accuracy class selection field with the appropriate classes
- Test Standard: Select which standard will be used when testing the VT. The user can select between the methods of ANSI or IEC methods.
- Accuracy Class: Use the drop down menu to select the VT accuracy class from available options such as

A vertical list of buttons for selecting VT ratings. The buttons are labeled 0.15, 0.15S, 0.3, 0.6, 1.2, 2.4, 4.8, and Add. A red 'X' icon is located at the bottom right of the list.

- VA: The VA rating of the VT can be obtained from the nameplate
- Burden The Burden rating of the VT can be obtained from the nameplate
- Primary Voltage
- Check box for Primary Phase to Ground
- Secondary Voltage
- Check box for Secondary Phase to Ground
- Check box for Secondary /3
- Ratio: For a multi- tap VT, different tap ratios can be obtained from nameplate and can be entered in nameplate screen. By entering both the primary voltage and the secondary voltage the MVCT can calculate the ratio
- User Descriptions and Values are used to fill out the optional testing information such as
 1. Technician name,
 2. Company information,
 3. Substation location,
 4. Position and phase of VT
 5. Other relevant testing data.

Note: Not All the information in Nameplate screen is optional. It is required to enter the Burden Rating and the secondary voltage to perform a test on VT. This allows MVCT to restrict voltage and prevent damage to wiring inside VT. By inputting proper data a more complete report can also be generated.

5.4.2.4 Home Screen

Within the “Home Screen “ selecting the VT TEST button will cause the button to turn bright yellow. This will inform the user that the MVCT is now in VT Testing mode. From here the user will have access

to the tests available for VT testing. With Basic VT Testing, the Ratio/Phase Error test and the Winding resistance test is available. If the MVCT is configured for Advanced VT Testing, in addition to the tests available in Basic, the MVCT will also have the Excitation/Saturation test, and the Short Circuit Impedance Test.

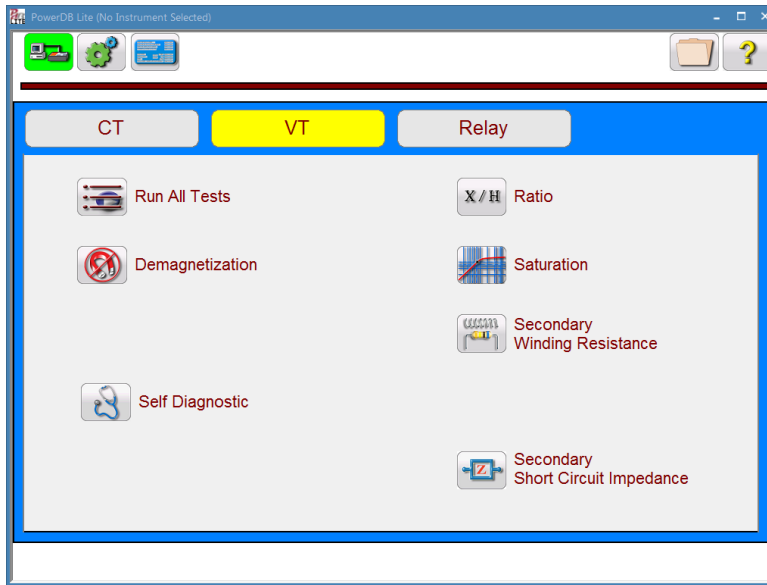


Figure 40 Home Screen VT Testing Mode

5.4.2.5 Run All Tests on VT



Selection of Run All Tests button will bring the user to the Test Configuration screen

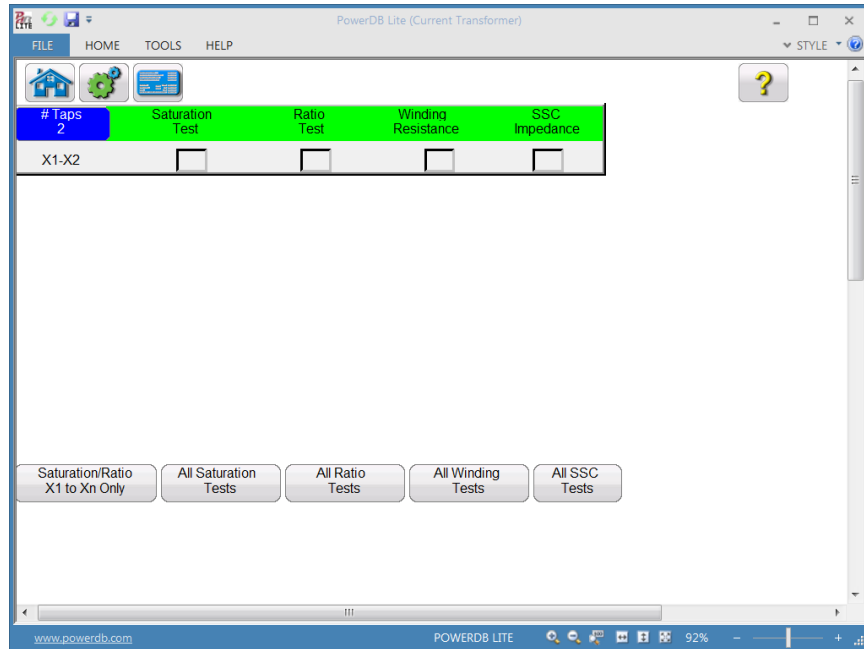
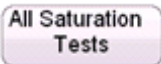


Figure 41 Run All Test Screen

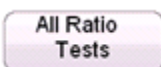
In order for the MVCT to estimate the performance of the VT, the MVCT must have the Advanced VT package installed and each test outlined in the Run All test screen must be performed on the VT. In the Basic VT testing the Saturation Test and Short Circuit Impedance Test are not available. The user can easily configure a test plan for a voltage transformer by checking the box adjacent to the desired test. The MVCT will then cycle through and perform each test. Please note though that a lead change may be required after completion of one test and before beginning of the next test. The MVCT will alert the user as to the proper connections for the upcoming test prior to the test beginning. Please closely evaluate each connection diagram and ensure the unit is properly connected before continuing.

**** Please note that both proper and improper connections during a test can result in an extremely dangerous environment being generated. The user should carefully read all safety precautions and understand them prior to beginning any testing. The user should also follow all connections diagrams and read the warnings on such in order to be aware of the environment.**

The various buttons at the bottom of the screen can also be used to easily configure a test:



Used to auto select Saturation Test on all windings



Used to auto select Ratio Test on all windings

All Winding Tests

Used to auto select Winding Resistance Test on all windings

All SSC Tests

Used to auto select Secondary Short Circuit Impedance test on all windings

5.4.2.6 Demagnetization



Selection of Demagnetization, brings the user to the following connection diagram .

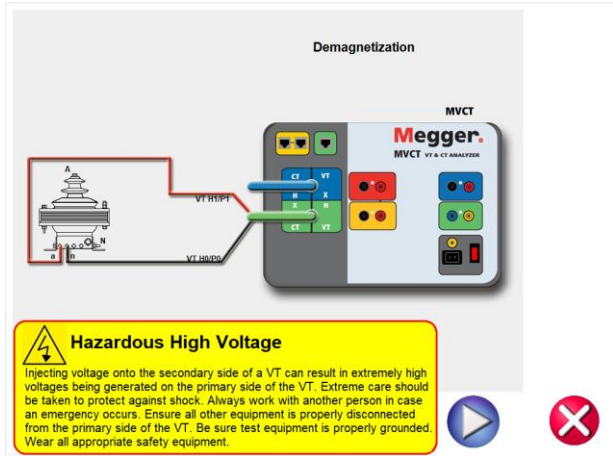


Figure 42 Demagnetization Connection Diagram

After confirming the connections are correct, continue with demagnetizing the VT by selecting the blue play button. The red X will cancel the operation.

After selecting to continue the operation, the user will be advised that the VT is being demagnetized

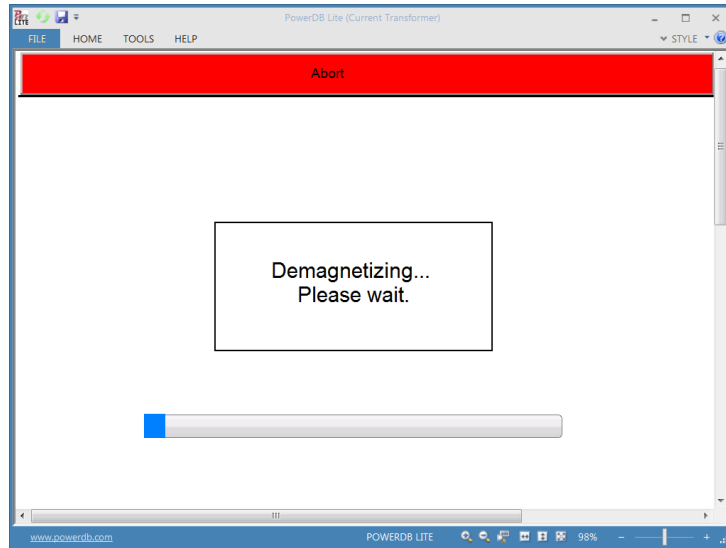


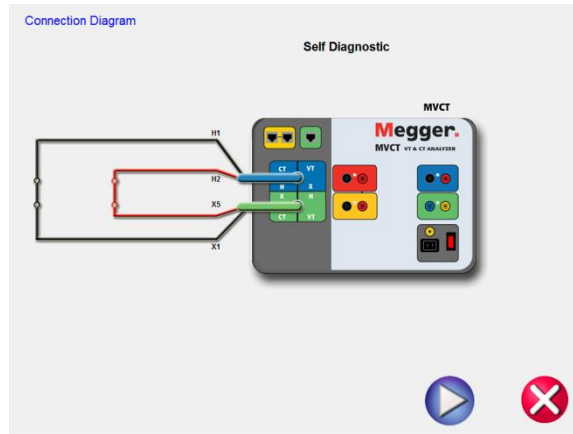
Figure 43 Demagnetization Process

Upon completion, the user will be returned to the Main Test Configure Screen and notified the demagnetization process is complete.

5.4.2.7 Self Test



Selection of the “Self Diagnostic” navigation button from the home screen will display a connection diagram



After the user has ensured the MVCT is connected properly as in the diagram, the self test is begun by selecting the blue play button



5.4.2.8 Ratio



Selection of **X/H** Ratio Test button from the test configuration screen will bring the user to the following Ratio Test screen

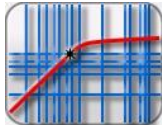


Figure 44 VT Ratio Test Screen

The ratio test is begun by selecting the blue play button.



5.4.2.9 Saturation



Selection of Saturation Test button from the test configuration screen will bring the user to the following Saturation Test screen

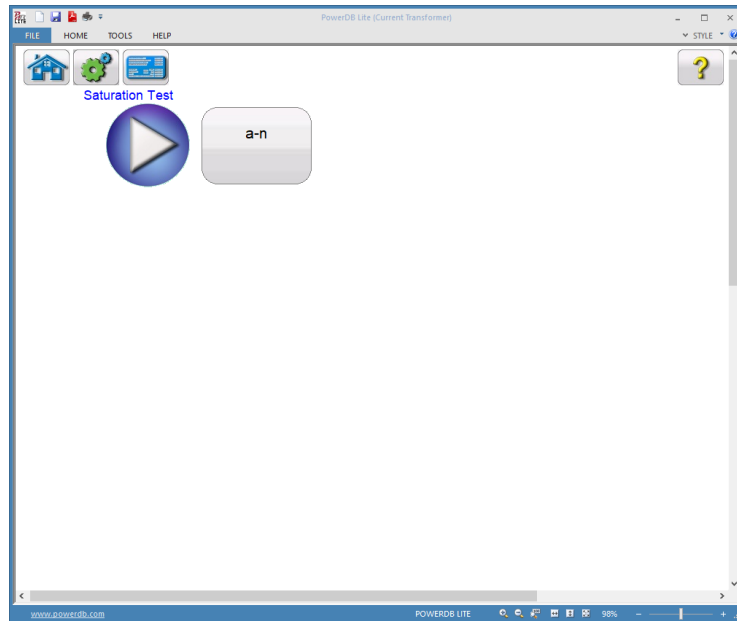


Figure 45 Saturation Test Screen

The Saturation test is begun by selecting the Blue Play button



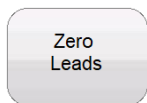
5.4.2.10 Winding Resistance



Selection of Winding Resistance Test button from the test configuration screen will bring the user to the following Winding Resistance Test screen.



Figure 46 VT Winding Resistance Test Screen



Use the Zero Leads button to zero out the leads from the measurement. This will ensure no resistance from the leads is included in the resistance measurement and improve the accuracy of the measurement.

The Winding Resistance test is begun by selecting the blue play button.



5.4.2.11 Secondary Short Circuit Impedance



Selection of Impedance Test button from the test configuration screen will bring the user to the following Secondary Short Circuit Impedance Test screen.

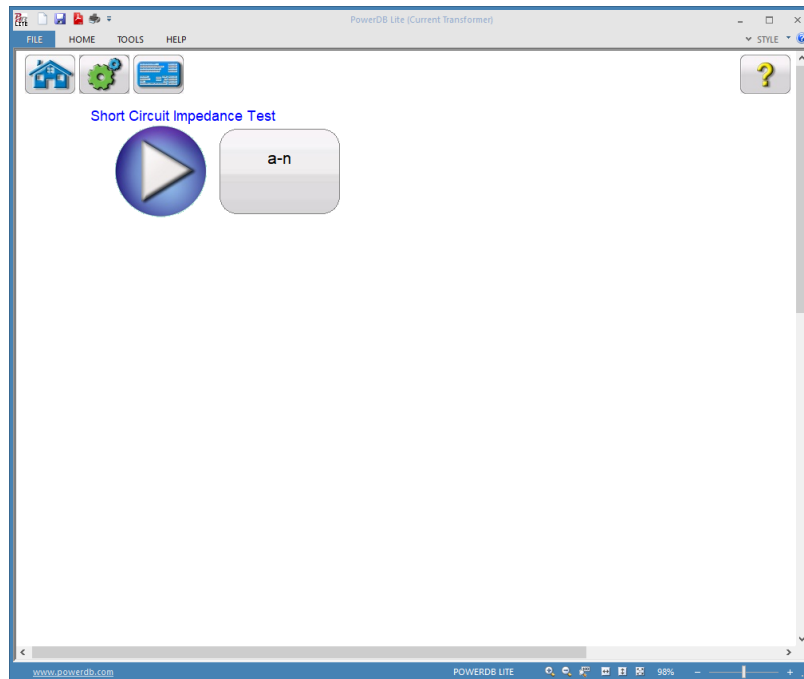


Figure 47 Short Circuit Impedance Test Screen

The Short Circuit Impedance is begun by selecting the Blue Play button



5.4.2.12 View Report



If a test has been completed and data is present the View Test Report button will be available. Selection of this button will generate a report of all test data for the active VTs. Data in the report regarding customer information may be entered here.

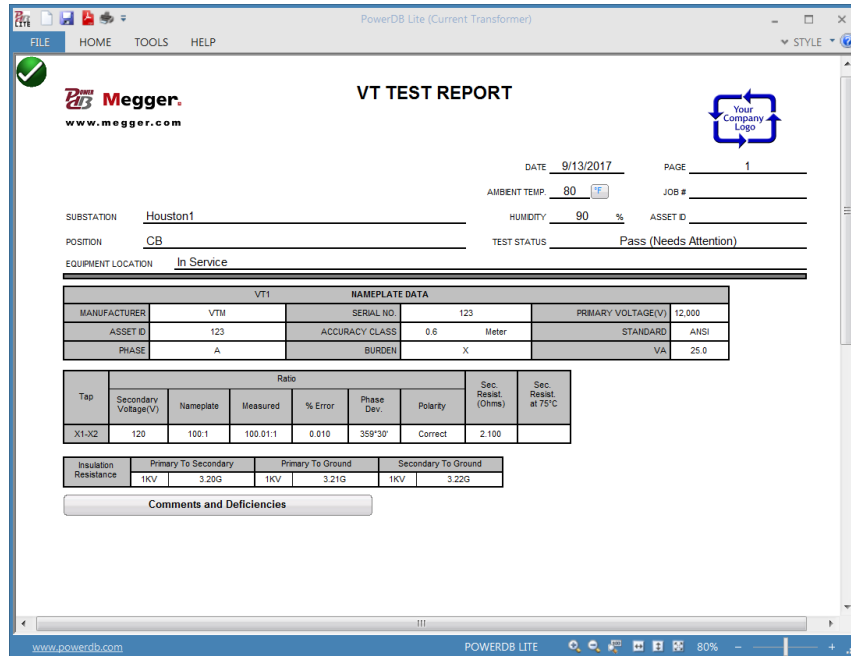
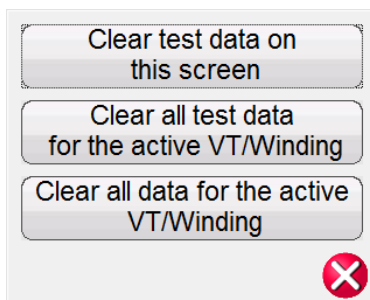


Figure 48 Sample VT Test Report

5.4.2.13 Delete Data



If a test has been completed and data is present; the Delete Test Data button will be available. Selection of this button activates the following dialog



This will allow the user three options of deleting data

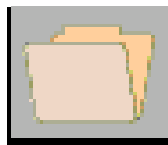
- Clear test data on screen will only clear the data of the test screen currently active
- Clear all test data for active VT will delete the test data for the active VT but not delete the nameplate information that has been entered
- Clear all data for active VT will delete all test data and nameplate information

5.4.2.14 Report Configuration

The MVCT will provide a concise one page report that will include all testing results. With the Basic VT Testing Option the report will include the data from the following tests: ratio; phase deviation; polarity; winding resistance. If the MVCT has the Advanced VT Option, in addition to the data from the previous tests, the report will also include testing data from the excitation/saturation test, and the short circuit impedance test. With the data from all the tests, The MVCT report can also be configured to provide additional data including the ratio and phase errors at various percentages of primary voltage and at different levels of burden. The option to include the ratio and phase error tables is a setting controlled in the device setting section.

5.4.2.15 File Operations

Files operations will vary depending upon whether the user is controlling the MVCT with a PowerDB installed on PC or the MVCT's integrated display. For units being controlled with the MVCT's integrated display, once a CT has been tested and a test file exists, the File Manager button will be available.



Selection of File Manager button, brings the user to the following tool bar



Figure 49 Testing - File Operation Tool Bar

The toolbar is used to Open File; Close File; or Cancel. Selecting either Open File or Close File will open the File Manager Dialog (see below)

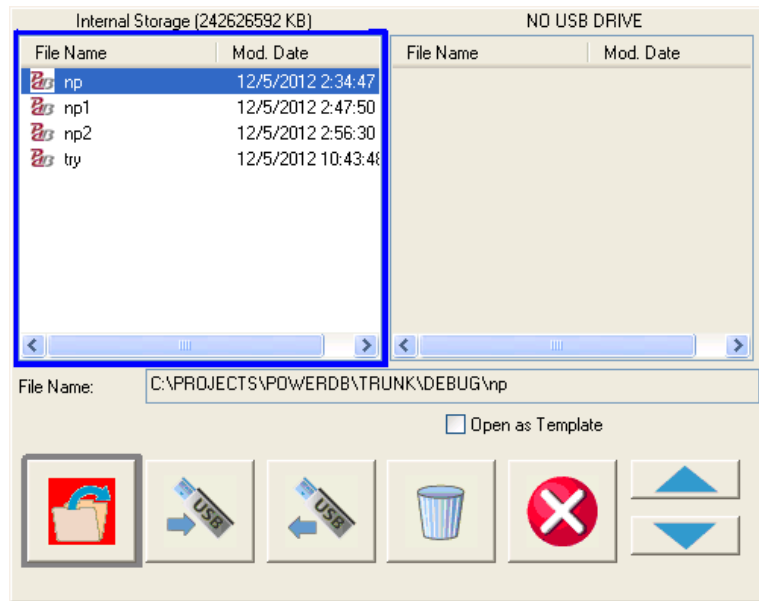


Figure 50 VT Testing: File Manager Screen

File manager screen is used to view and access the stored test results. All stored test results are displayed in alphabetical order along with date and time stampings.

Function buttons are used to recall, delete or transfer the test results. The function buttons are used to manage files as below:



Used to open file highlighted in the internal storage list



Used to save file named in edit box to system memory



Used to transfer file highlighted in the internal storage list to a USB stick



Used to transfer file highlighted in the USB drive list to internal system



Used to delete file highlighted in internal storage list



Cancels operation and closes dialog



Used to scroll file selection highlight up and down

If the MVCT is being controlled using PowerDb installed on a PC, then a different interface is available for file operations.

VT TEST REPORT

DATE: 9/13/2017 PAGE: 1

AMBIENT TEMP: 80 F JOB #:

SUBSTATION: Houston1 HUMIDITY: 90% ASSET ID:

POSITION: CB TEST STATUS: Pass (Needs Attention)

EQUIPMENT LOCATION: In Service

VT1		NAMEPLATE DATA			
MANUFACTURER	VTM	SERIAL NO.	123	PRIMARY VOLTAGE(V)	12,000
ASSET ID	123	ACCURACY CLASS	0.6	Meter	STANDARD
PHASE	A	BURDEN	X	VA	25.0

Tap	Ratio						Sec. Resist. (Ohms)	Sec. Resist. at 75°C
	Secondary Voltage(V)	Nameplate	Measured	% Error	Phase Dev.	Polarity		
X1-X2	120	100:1	100.01:1	0.010	359'30"	Correct	2.100	

Insulation Resistance	Primary To Secondary		Primary To Ground		Secondary To Ground	
	1KV	3.20G	1KV	3.21G	1KV	3.22G

Comments and Deficiencies

Access to the file operations is gained through the FILE tab in the PowerDB window.

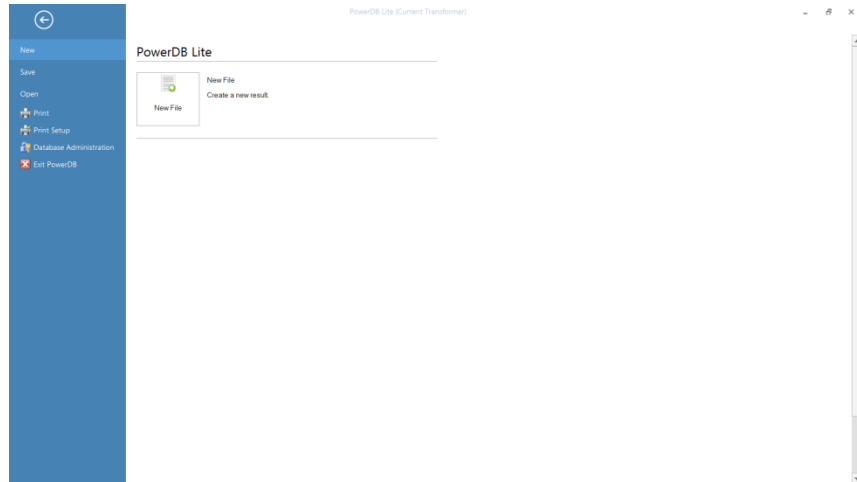


Figure 51 VT Testing: File Save from PC

From here the user can create a New File, Save the current File, open an existing File, or print the existing file.

5.4.3 Relay Testing Mode

Selection of the Relay testing mode will bring the user to a new system Log on screen

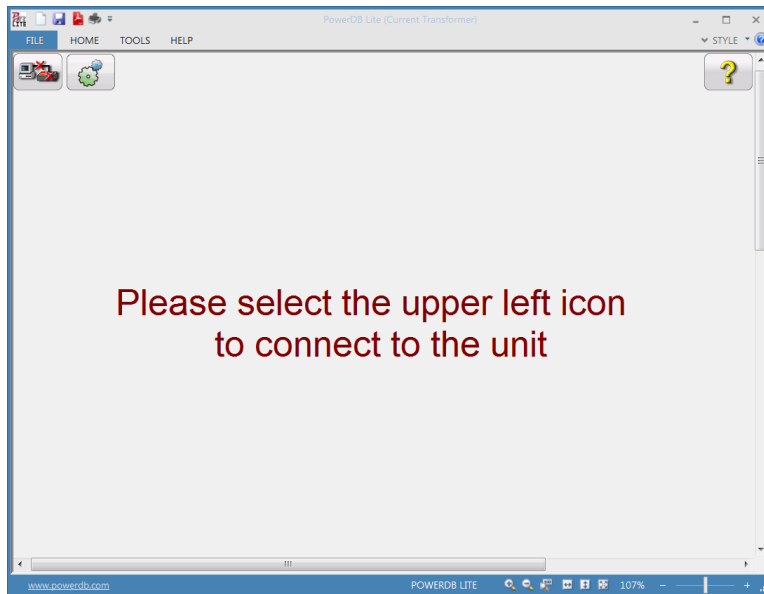


Figure 52 Relay Testing System Log On

Selection of the network button in the top left corner of the window will log the user onto the MVCT's relay testing mode of operation.

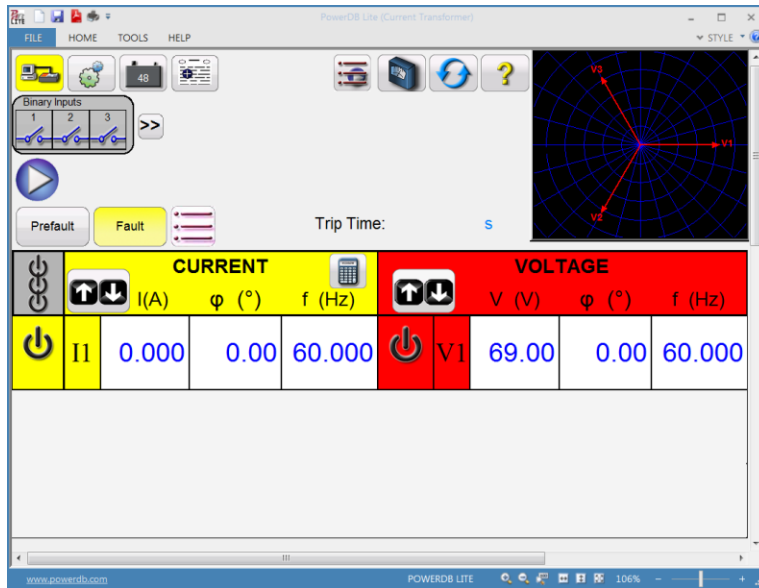


Figure 53 Relay Testing Screen

For proper operation and control of the relay testing functionality, please refer to the User Guide for Megger's SMRT1 Single Phase Relay Test System

6.0 Testing CT with MVCT

6.1 Test Plan Creation

Refer to the safety instructions first before use of the equipment.

1. Verify the Power ON/OFF switch is OFF. Power the test set from a suitable source of power (95-265 V50/60 Hz).
2. Connect the ground wing nut to a suitable ground.

WARNING

There is always the possibility of voltages being induced at the terminals of a test specimen because of proximity to high voltage energized lines. A residual static voltage charge may also be present at these terminals. Ground each terminal to be tested with a safety ground stick, before making connections.

3. On test lead set labeled CT X/S connect the high voltage connector color coded green to the MVCT high voltage connector that is color coded green and labeled **SOURCE** Voltage. Use the red alignment marks on the 2 connectors to properly align them before connecting.
4. On test lead set labeled CT H/P Connect the high voltage connector color coded blue to the MVCT high voltage connector that is color coded blue and labeled **MEASUREMENT**. Use the red alignment mark on the 2 connectors to properly align them before connecting

5. On test lead set labeled CT X/S connect the test lead binding posts X1 X2, X3, X4 and XN to secondary of the current transformer X1, X2, X3, X4 and X5 (if less than 5 taps are available on the CT, then connect the test set secondary output binding posts X1, X2... to the correlating secondary of the current transformer with the EXCEPTION of connecting the test set secondary output binding Xn to the most external secondary of the current transformer. For Example on a 3 Tap CT Connect X1(test set) to X1(CT), X2(test set) to X2 (CT), and Xn (test set) to X3 (CT)
6. On test lead set labeled CT H/P connect the test lead primary binding posts H1 and H2 to CT primary bushings H1 and H2.Observe the polarity marks on the CT (H1 on the test set is polarity terminal).

WARNING

The MVCT produces high voltages and currents during the performance of tests. DO NOT TOUCH connector clips or test leads while the MVCT is performing a test.

7. Turn Power ON/OFF switch to ON
8. After the boot up, select the “Nameplate Information” menu by selecting



Name Plate navigation button.

9. Fill in nameplate information about the CT. At a minimum, the number of taps and the secondary current must be selected
10. In the Home Screen, select the Run All Tests button. Within the Run All Test screen select all of the desired tests by placing a check in the adjacent box

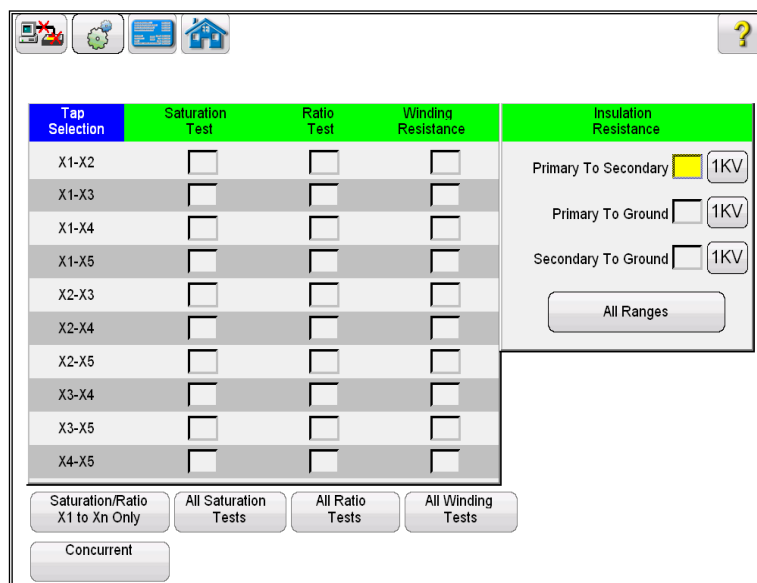


Figure 54 Run All Tests – Configuration

- Select the individual taps for saturation testing by placing a check in the corresponding

box. Or select all taps by selecting the  button. This will place a check corresponding to all taps.

- Select the individual taps for ratio testing by placing a check in the corresponding

box. Or select all taps by selecting the  button. This will place a check corresponding to all taps.

- Select the individual taps for Winding Res testing by placing a check in the corresponding

box. Or select all taps by selecting the  button. This will place a check corresponding to all taps.

- Place a check in the corresponding box next to each desired insulation test – Primary to Secondary, Primary to Ground, and Secondary to Ground.

- Select the desired voltage range to conduct the insulation test; either 500V or 1KV

- At this point, this test file could be saved, opened at a later date , and ran.

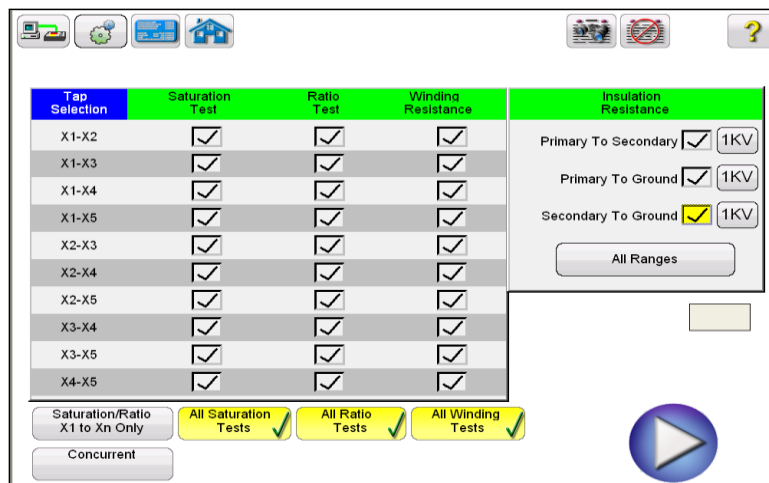


Figure 55 Test Plan - Multi Tap

- The test plan can be ran at this time by selecting the Blue Play button



18. A connection diagram will appear showing how to properly connect the MVCT to the CT

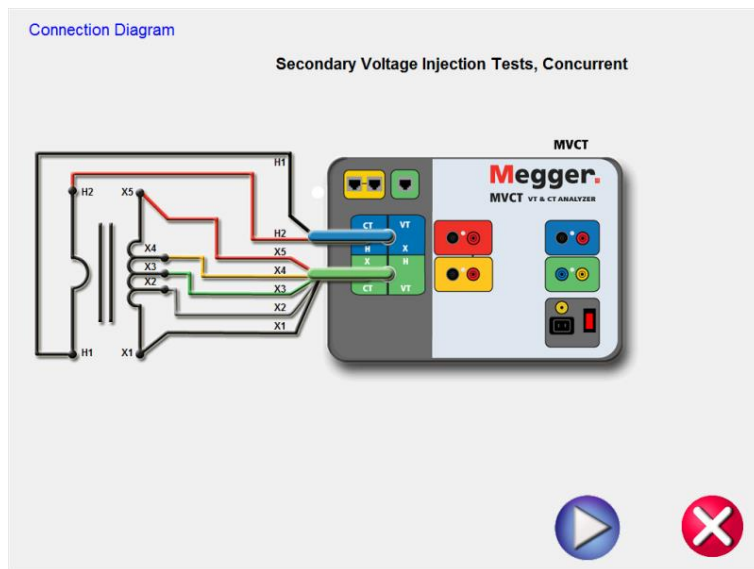


Figure 56 CT Connection Diagram Multi Tap: Concurrent

19. Continue the test by selecting the Blue Play button



20. At any point of time Test can be terminated by hitting the ABORT button at the top of any testing screen.

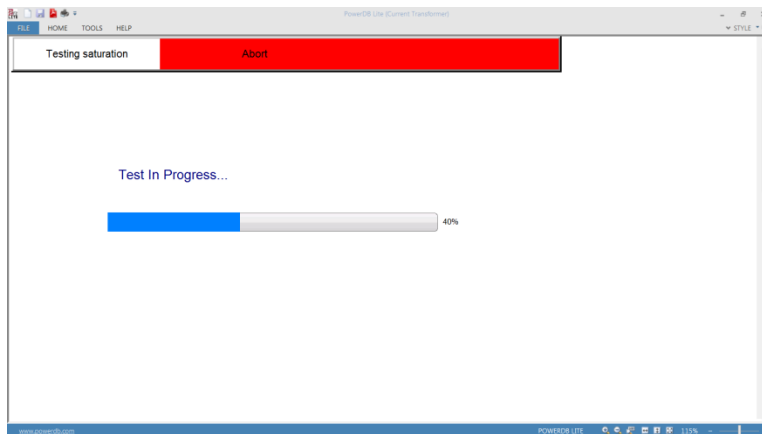


Figure 57 CT Saturation Testing Screen: Concurrent

21. Upon completion of test, the results will be displayed in a test report

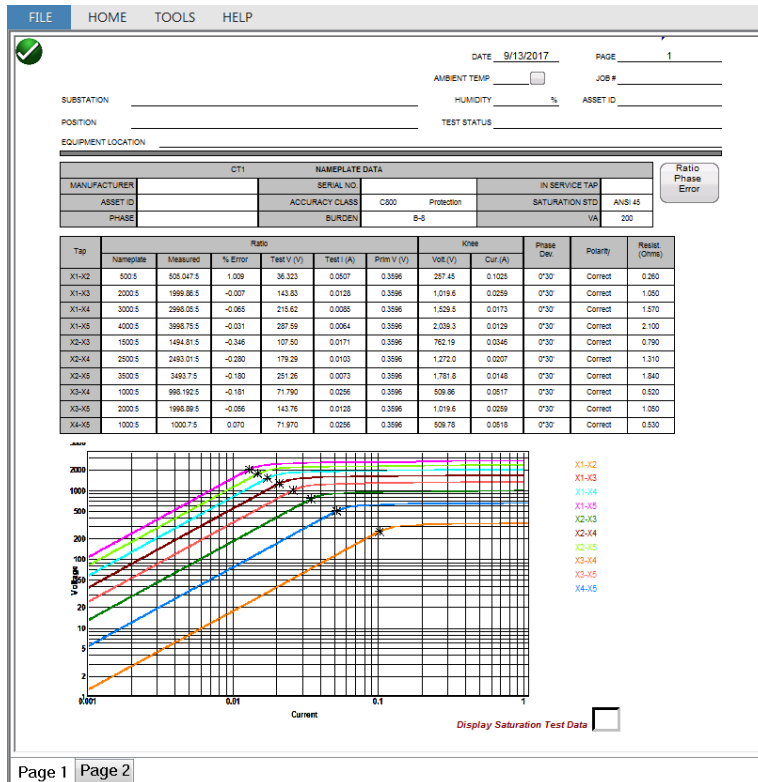


Figure 58 CT Test Report - Concurrent

6.2 CT Saturation Test

6.2.1 Method 1 – Concurrent

Refer to the safety instructions first before use of the equipment.

1. Verify the Power ON/OFF switch is OFF. Power the test set from a suitable source of power (95-265 V50/60 Hz).
2. Connect the ground wing nut to a suitable ground.

WARNING

There is always the possibility of voltages being induced at the terminals of a test specimen because of proximity to high voltage energized lines. A residual static voltage charge may also be present at these terminals. Ground each terminal to be tested with a safety ground stick, before making connections.

3. On test lead set labeled CT X/S connect the high voltage connector color coded green to the MVCT high voltage connector that is color coded green and labeled **SOURCE** Voltage. Use the red alignment marks on the 2 connectors to properly align them before connecting.

4. On test lead set labeled CT H/P Connect the high voltage connector color coded blue to the MVCT high voltage connector that is color coded blue and labeled **MEASUREMENT**. Use the red alignment mark on the 2 connectors to properly align them before connecting
5. On test lead set labeled CT X/S connect the test lead binding posts X1 X2, X3, X4 and XN to secondary of the current transformer X1, X2, X3, X4 and X5 (if less than 5 taps are available on the CT, then connect the test set secondary output binding posts X1, X2... to the correlating secondary of the current transformer with the EXCEPTION of connecting the test set secondary output binding Xn to the most external secondary of the current transformer. For Example on a 3 Tap CT Connect X1(test set) to X1(CT), X2(test set) to X2 (CT), and Xn (test set) to X3 (CT)
6. On test lead set labeled CT H/P connect the test lead primary binding posts H1 and H2 to CT primary bushings H1 and H2.Observe the polarity marks on the CT (H1 on the test set is polarity terminal).

WARNING

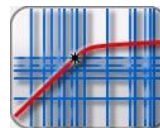
The MVCT produces high voltages and currents during the performance of tests. DO NOT TOUCH connector clips or test leads while the MVCT is performing a test.

7. Turn Power ON/OFF switch to ON
8. After the boot up, select the “Nameplate Information” menu by selecting



Name Plate navigation button.

9. Fill in nameplate information about the CT. At a minimum, the number of taps and secondary current must be selected



10. From the Home Screen select the “Saturation Test” button.

11. In the saturation test screen, selecting the Concurrent Mode of operation will allow the user to test multiple taps in parallel.

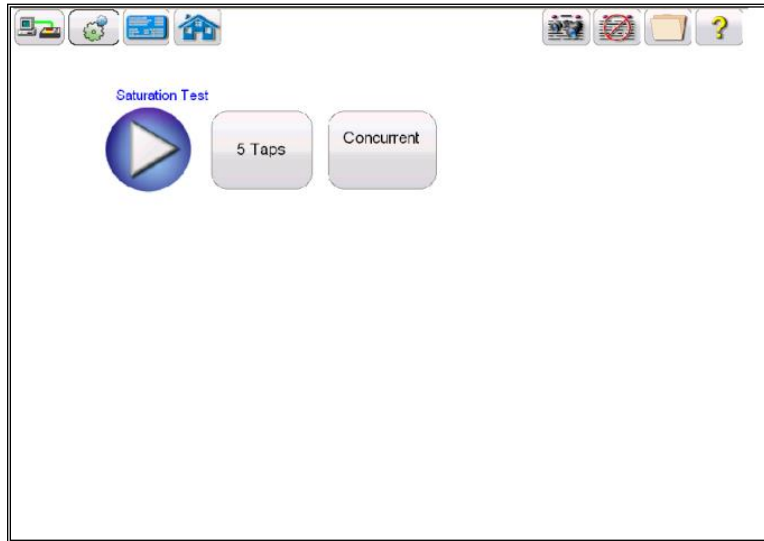


Figure 59 CT Saturation Test Screen - Concurrent

12. Select the play button and a connection diagram will appear showing the proper connections for the MVCT to the CT

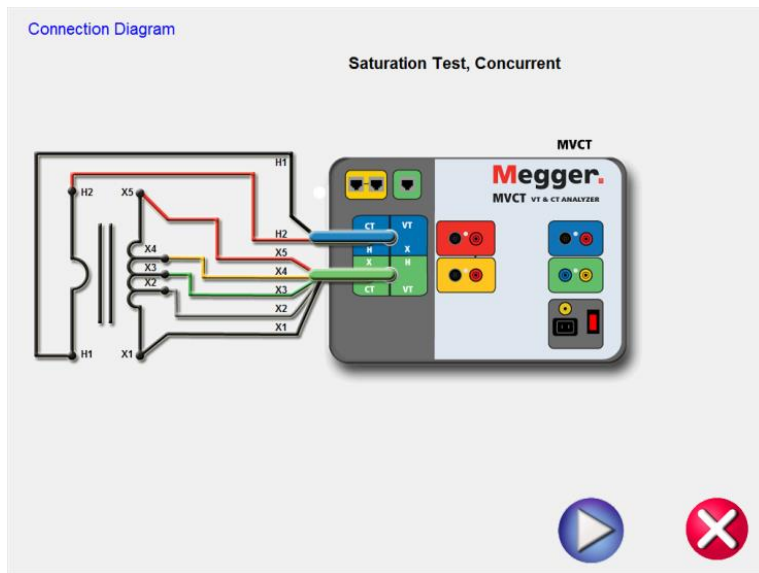


Figure 60 CT Saturation Connection Diagram - Concurrent

13. Check all connections to ensure correctness
14. Hit Blue Play button to begin test.



15. The saturation test will begin.

- ⇒ X Voltage (V): The MVCT displays the real time voltage readings of the secondary X winding while the test is in progress.
- ⇒ X Current (A): The MVCT the real time current readings for the secondary X winding while the test is in progress.
- ⇒ Saturation Curve: The excitation curve is Log-Log curve with secondary current on X coordinate and secondary voltage on Y coordinate. Saturation curves for all correlating taps will be graphed in the chart in the right hand corner of the screen in real time as data is accumulated.

16. At any point of time Test can be terminated by hitting the ABORT button at the top of the screen.

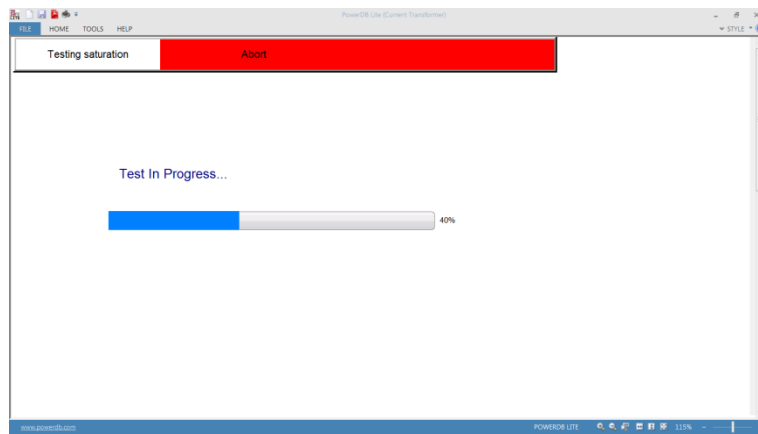


Figure 61 CT Saturation Testing Screen – Concurrent

17. Upon completion of test, the results can be viewed in the test screen or in a test report.

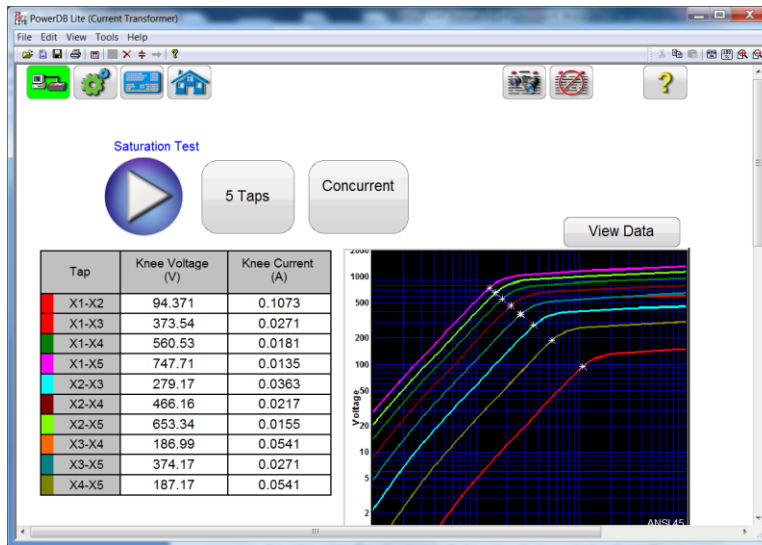


Figure 62 CT Saturation Results Screen - Concurrent

Saturation points: The unit automatically determines the knee point based upon the user selected standard (ANSI 30, ANSI 45 or IEC 60044-1). Saturation voltage and saturation current corresponding to that knee point are displayed along with other results at the completion of the test.

6.2.2 Method 2 – Non Concurrent or Testing a Single Tap

Refer to the safety instructions first before use of the equipment.

1. Verify the Power ON/OFF switch is OFF. Power the test set from a suitable source of power (95-125 or 195-265 V50/60 Hz).
2. Connect the ground wing nut to a suitable ground.

WARNING

There is always the possibility of voltages being induced at the terminals of a test specimen because of proximity to high voltage energized lines. A residual static voltage charge may also be present at these terminals. Ground each terminal to be tested with a safety ground stick, before making connections.

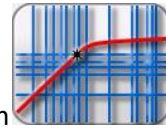
3. On test lead set labeled CT X/S connect the high voltage connector color coded green to the MVCT high voltage connector that is color coded green and labeled **SOURCE** Voltage. Use the red alignment marks on the 2 connectors to properly align them before connecting.

4. On test lead set labeled CT H/P Connect the high voltage connector color coded blue to the MVCT high voltage connector that is color coded blue and labeled **MEASUREMENT**. Use the red alignment mark on the 2 connectors to properly align them before connecting
5. On test lead set labeled CT X/S connect the test lead binding posts X1 and X5 to secondary of the current transformer on the desired tap. Observe the polarity marks on the CT (X1 on test set is polarity terminal).
6. On test lead set labeled CT H/P connect the test lead primary binding posts H1 and H2 to CT primary bushings H1 and H2. Observe the polarity marks on the CT (H1 on the test set is polarity terminal).

WARNING

The MVCT produces high voltages and currents during the performance of tests. DO NOT TOUCH connector clips or test leads while the MVCT is performing a test.

7. Turn Power ON/OFF switch to ON.



8. After the boot up, in the Home Screen select the “Saturation Test” button

9. In the saturation test screen, deselect the Concurrent Mode of operation. This will allow the user to conduct a saturation test upon an individual tap

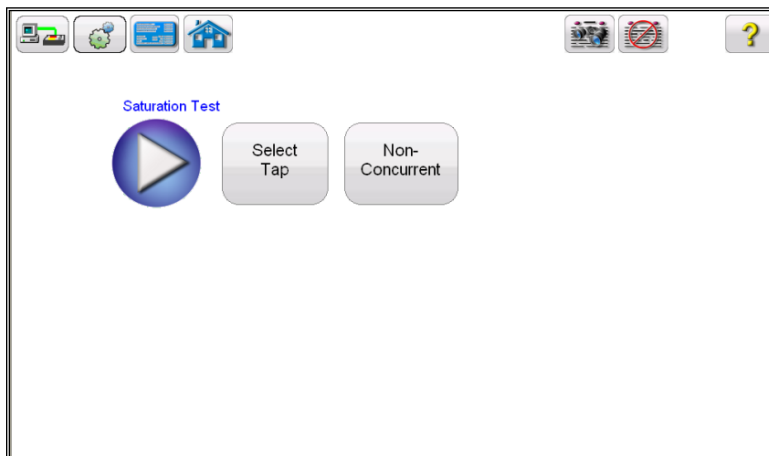
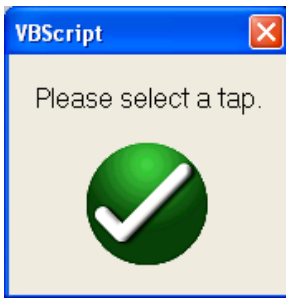


Figure 63 CT Saturation Test Screen – Non Concurrent

10. Hit the Select Tap function button to select the appropriate tap to be tested



11. Select the tap configuration before hitting the PLAY button. If PLAY button is pressed before selecting the tap, following message will appear:



12. After selecting the appropriate tap, select the play button and a connection diagram will appear showing how to correctly connect the MVCT to the CT

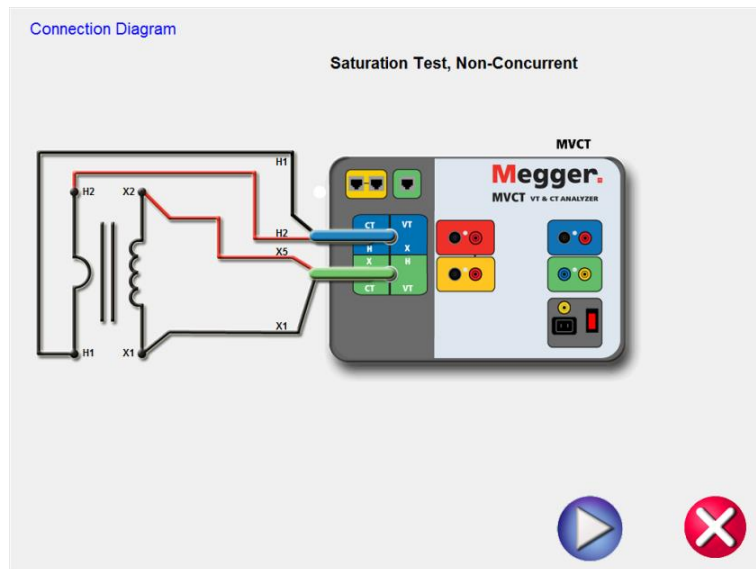


Figure 64 CT Saturation Connection Diagram - Non Concurrent

13. Check all connections to ensure correctness



14. Hit Blue Play button to begin test.

- ⇒ The saturation will begin. X Voltage (V): The MVCT displays the real time voltage readings of the secondary X winding while the test is in progress.
- ⇒ X Current (A): The MVCT the real time current readings for the secondary X winding while the test is in progress.
- ⇒ Saturation Curve: The excitation curve is Log-Log curve with secondary current on X coordinate and secondary voltage on Y coordinate. Saturation curves for all correlating taps will be graphed in the chart in the right hand corner of the screen in real time as data is accumulated.

15. At any point of time Test can be terminated by hitting the ABORT button at the top of the screen.

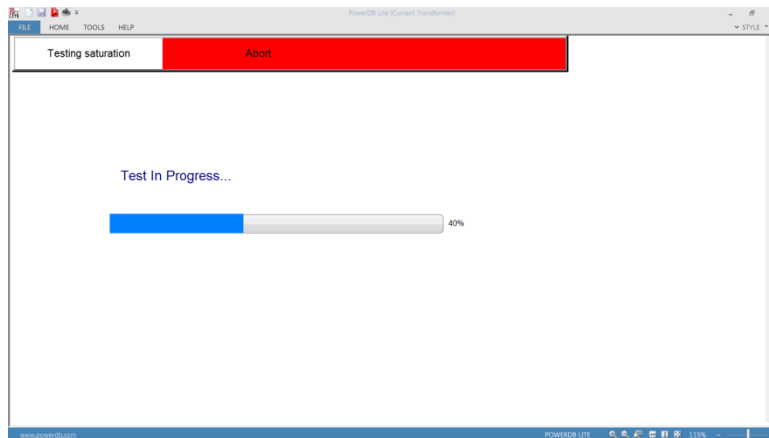


Figure 65 CT Saturation Test Screen Non Concurrent

16. Upon completion of test the results will be displayed in the test screen or it can be displayed



in a test report by selecting the view report button

17. Saturation points: The unit automatically determines the knee point based upon the user selected standard (ANSI 30, ANSI 45 or IEC 60044-1). Saturation voltage and saturation current corresponding to that knee point are displayed along with other results at the completion of the test.

6.3 Ratio Test

6.3.1 Method 1 – Concurrent

Connections for the test set:

Refer to the safety instructions first before use of the equipment.

1. Verify the Power ON/OFF switch is OFF. Power the test set from a suitable source of power (95-265 V/50/60 Hz).
2. Connect the ground wing nut to a suitable ground.

WARNING

There is always the possibility of voltages being induced at the terminals of a test specimen because of proximity to high voltage energized lines. A residual static voltage charge may also be present at these terminals. Ground each terminal to be tested with a safety ground stick, before making connections.

3. On test lead set labeled CT X/S connect the high voltage connector color coded green to the MVCT high voltage connector that is color coded green and labeled **SOURCE** Voltage. Use the red alignment marks on the 2 connectors to properly align them before connecting.
4. On test lead set labeled CT H/P Connect the high voltage connector color coded blue to the MVCT high voltage connector that is color coded blue and labeled **MEASUREMENT**. Use the red alignment mark on the 2 connectors to properly align them before connecting
5. On test lead set labeled CT X/S connect the test lead binding posts X1 X2, X3, X4 and XN to secondary of the current transformer X1, X2, X3, X4 and X5 (if less than 5 taps are available on the CT, then connect the test set secondary output binding posts X1, X2... to the correlating secondary of the current transformer with the EXCEPTION of connecting the test set secondary output binding Xn to the most external secondary of the current transformer. For Example on a 3 Tap CT Connect X1(test set) to X1(CT), X2(test set) to X2 (CT), and Xn (test set) to X3 (CT)
6. On test lead set labeled CT H/P connect the test lead primary binding posts H1 and H2 to CT primary bushings H1 and H2.Observe the polarity marks on the CT (H1 on the test set is polarity terminal).

WARNING

The MVCT produces high voltages and currents during the performance of tests. DO NOT TOUCH connector clips or test leads while the MVCT is performing a test.

7. Turn Power ON/OFF switch to ON

- After the boot up, select the “Nameplate Information” menu by selecting



Name Plate navigation button.

- Fill in nameplate information about the CT. At a minimum, the number of taps and secondary current must be selected



- From the Home Screen select the “Ratio Test” button
- In the Ratio test screen, selecting the Concurrent Mode of operation will allow the user to test multiple taps in parallel.



Figure 66 CT Ratio Test Screen – Concurrent

- Select the play button and a connection diagram will appear showing the proper connections for the MVCT to the CT

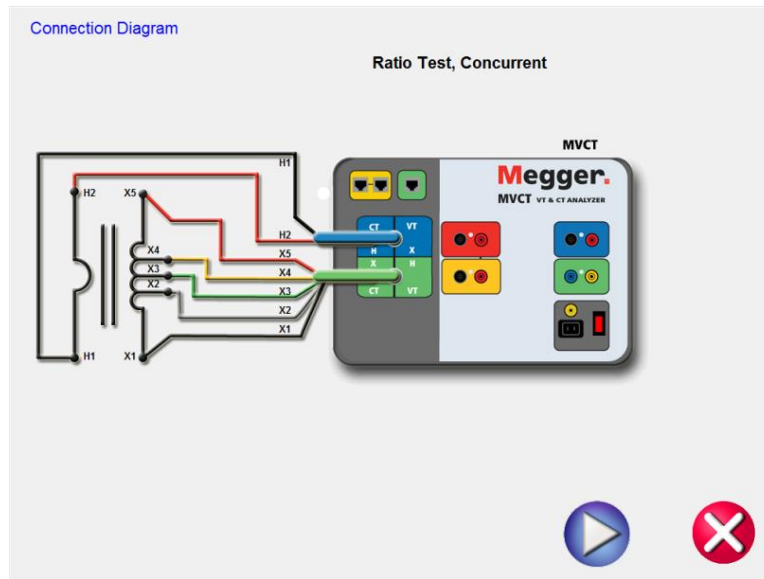


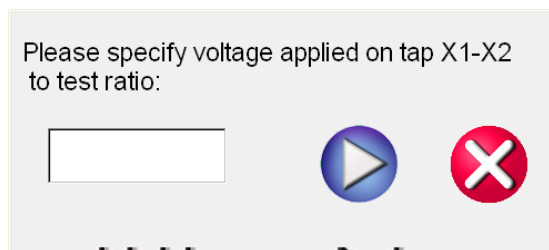
Figure 67 CT Ratio Connection Diagram - Concurrent

13 Check all connections to ensure correctness

14 Hit Blue Play button.



15 A dialog will appear requesting how much Voltage to apply to the CT during the ratio test



16 Enter a voltage 1V and 300V that is less than the knee point of the CT

17 Hit Blue Play button to begin test.



18 The Ratio Test will begin.

- ⇒ X Voltage (V): The MVCT displays the real time voltage readings of the secondary X winding while the test is in progress.
- ⇒ X Current (A): The MVCT the real time current readings for the secondary X winding while the test is in progress.
- ⇒ H Voltage (V): The MVCT the real time voltage readings of the primary H winding while the test is in progress.

18. At any point of time Test can be terminated by hitting the ABORT button at the top of the screen.

Testing ratio		ABORT	
Tap	Current (A)	Voltage (V)	H Voltage (V)
X1-X2	0.064	46.220	0.463
X1-X3	0.016	185.83	
X1-X4	0.011	277.49	
X1-X5	0.008	370.58	
X2-X3	0.021	139.61	
X2-X4	0.013	231.27	
X2-X5	0.009	324.36	
X3-X4	0.032	91.660	
X3-X5	0.016	184.75	
X4-X5	0.032	93.090	

Figure 68 CT Ratio Test Abort

19. Upon completion of test, the results can be viewed in the test screen or in a test report.

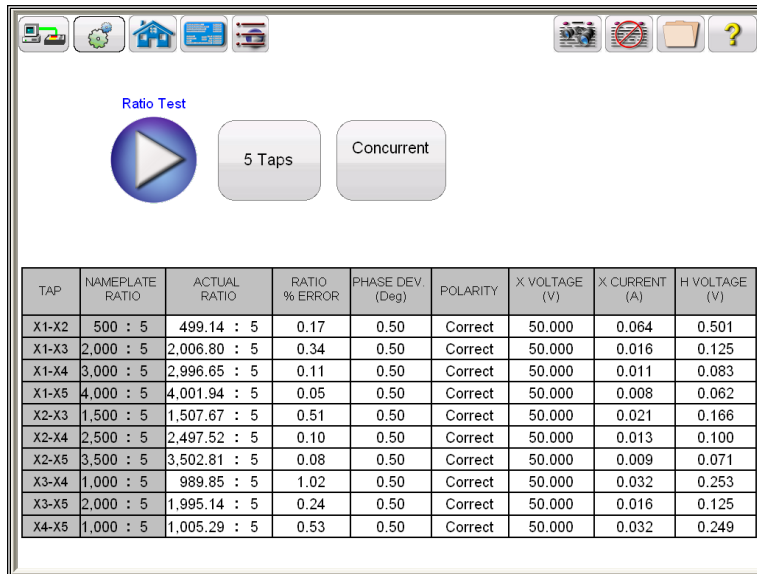


Figure 69 CT Ratio Test Results - Concurrent

Polarity: Unit automatically determines the polarity connections and displays the result as either polarity Correct or Incorrect. The phase angle deviation between the secondary and primary voltage is also displayed along with polarity.

The ratio is defined as the number of turns in the secondary as compared to the number of turns in the primary.

$$N2/N1=V2/V1$$

Where,

N2 and N1 are no. of turns of secondary and primary windings respectively

V2 and V1 are the secondary and primary side voltage readings respectively.

A suitable voltage, below saturation is applied to the secondary of the CT under test and primary side voltage is measured to calculate the turns ratio from above expression.

6.3.2 Method 2 – Non Concurrent or Testing a Single Tap

Refer to the safety instructions first before use of the equipment.

1. Verify the Power ON/OFF switch is OFF. Power the test set from a suitable source of power (95-125 or 195-265 V50/60 Hz).
2. Connect the ground wing nut to a suitable ground.

WARNING

There is always the possibility of voltages being induced at the terminals of a test specimen because of proximity to high voltage energized lines. A residual static voltage charge may also be present at these terminals. Ground each terminal to be tested with a safety ground stick, before making connections.

3. On test lead set labeled CT X/S connect the high voltage connector color coded green to the MVCT high voltage connector that is color coded green and labeled **SOURCE** Voltage. Use the red alignment marks on the 2 connectors to properly align them before connecting.
4. On test lead set labeled CT H/P Connect the high voltage connector color coded blue to the MVCT high voltage connector that is color coded blue and labeled **MEASUREMENT**. Use the red alignment mark on the 2 connectors to properly align them before connecting
5. On test lead set labeled CT X/S connect the test lead binding posts X1 and X5 to secondary of the current transformer on the desired tap. Observe the polarity marks on the CT (X1 on test set is polarity terminal).
6. On test lead set labeled CT H/P connect the test lead primary binding posts H1 and H2 to CT primary bushings H1 and H2. Observe the polarity marks on the CT (H1 on the test set is polarity terminal).

WARNING

The MVCT produces high voltages and currents during the performance of tests. DO NOT TOUCH connector clips or test leads while the MVCT is performing a test.

7. Turn Power ON/OFF switch to ON.



8. After the boot up, in the Home Screen select the "Ratio Test" button .
9. In the Ratio test screen, deselect the Concurrent Mode of operation. This will allow the user to conduct a saturation test upon an individual tap

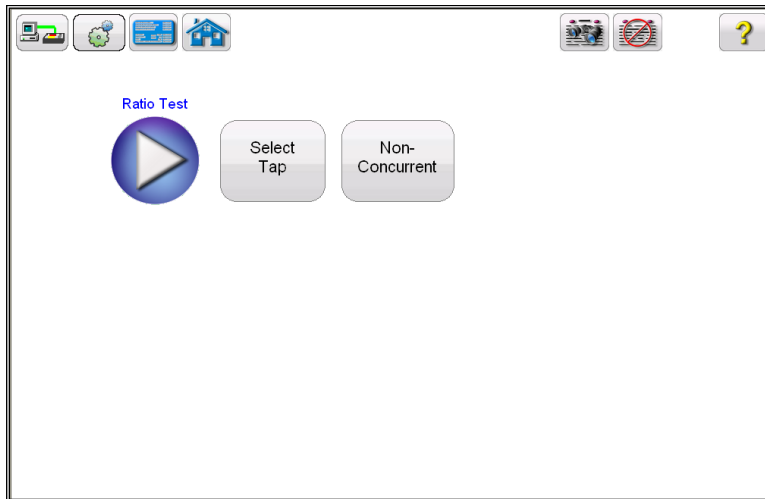
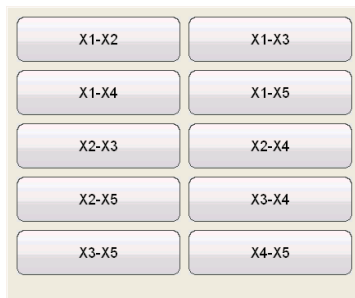
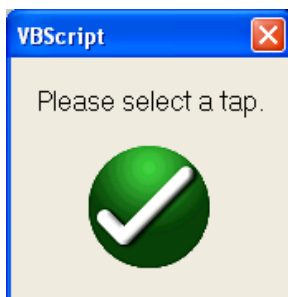


Figure 70 CT Ratio Test Screen – Non Concurrent

10. Hit the Select Tap function button to select the appropriate tap to be tested



11. Select the tap configuration before hitting the PLAY button. If PLAY button is pressed before selecting the tap, following message will appear:



- After selecting the appropriate tap, select the play button and a connection diagram will appear showing how to correctly connect the MVCT to the CT

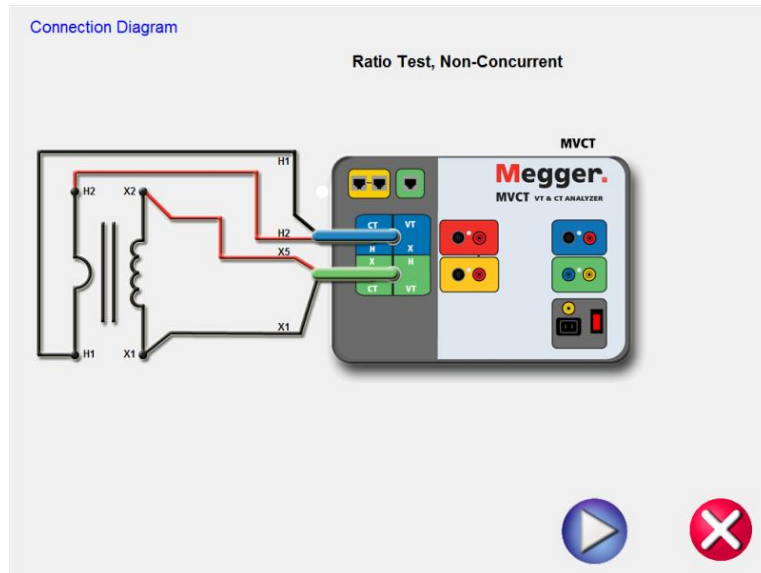


Figure 71 CT Ratio Test Connection Diagram - Non Concurrent



- Check all connections to ensure correctness

- Hit Blue Play button.



- A dialog will appear requesting how much Voltage to apply to the CT during the ratio test

Please specify voltage applied on tap X1-X2 to test ratio:

- Enter a voltage between 1V and 300V that is less than the knee point of the CT

- Hit Blue Play button to begin test.



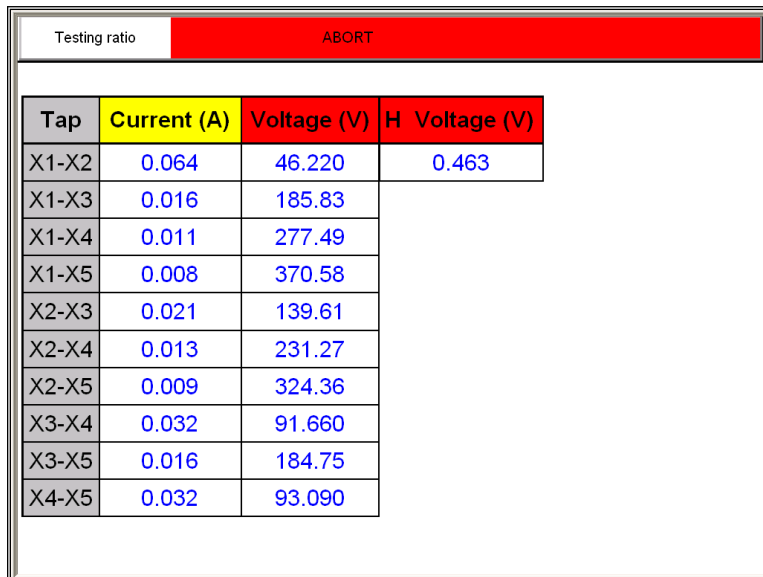
- The Ratio test will begin.

X Voltage (V): The MVCT displays the real time voltage readings of the secondary X winding while the test is in progress.

X Current (A): The MVCT the real time current readings for the secondary X winding while the test is in progress.

H Voltage (V): The MVCT the real time voltage readings of the primary H winding while the test is in progress.

19. At any point of time Test can be terminated by hitting the ABORT button at the top of the screen.



Testing ratio	ABORT		
Tap	Current (A)	Voltage (V)	H Voltage (V)
X1-X2	0.064	46.220	0.463
X1-X3	0.016	185.83	
X1-X4	0.011	277.49	
X1-X5	0.008	370.58	
X2-X3	0.021	139.61	
X2-X4	0.013	231.27	
X2-X5	0.009	324.36	
X3-X4	0.032	91.660	
X3-X5	0.016	184.75	
X4-X5	0.032	93.090	

Figure 72 CT Ratio Testing Screen - Abort

20. Upon completion of all test the results will be displayed in the test screen or they can be displayed in a test report.

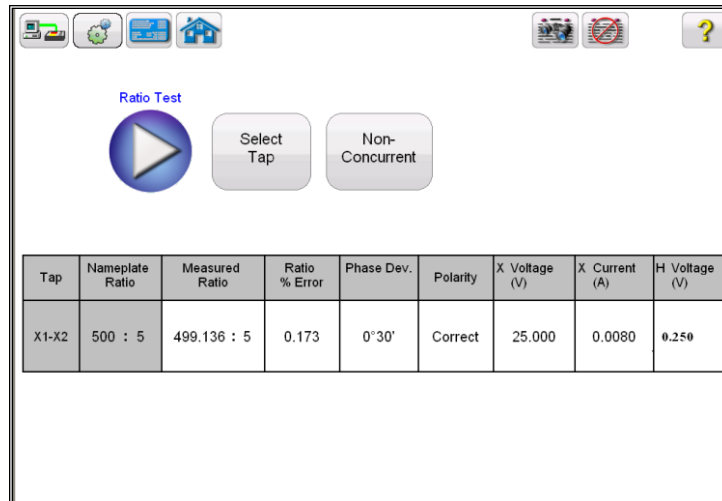


Figure 73 CT Ratio Test Results – Non Concurrent

Polarity: Unit automatically determines the polarity connections and displays the result as either polarity Correct or Incorrect. The phase angle deviation between the secondary and primary voltage is also displayed along with polarity.

The ratio is defined as the number of turns in the secondary as compared to the number of turns in the primary.

$$N2/N1=V2/V1$$

Where,

N2 and N1 are no. of turns of secondary and primary windings respectively

V2 and V1 are the secondary and primary side voltage readings respectively.

A suitable voltage, below saturation is applied to the secondary of the CT under test and primary side voltage is measured to calculate the turns ratio from above expression.

6.4 CT Winding Resistance Test:

6.4.1 Method 1 – Concurrent

Refer to the safety instructions first before use of the equipment.

1. Verify the Power ON/OFF switch is OFF. Power the test set from a suitable source of power (95-265 V50/60 Hz).
2. Connect the ground wing nut to a suitable ground.

WARNING

There is always the possibility of voltages being induced at the terminals of a test specimen because of proximity to high voltage energized lines. A residual static voltage charge may also be present at these terminals. Ground each terminal to be tested with a safety ground stick, before making connections.

3. On test lead set labeled CT X/S connect the high voltage connector color coded green to the MVCT high voltage connector that is color coded green and labeled **SOURCE** Voltage. Use the red alignment marks on the 2 connectors to properly align them before connecting.
4. On test lead set labeled CT H/P Connect the high voltage connector color coded blue to the MVCT high voltage connector that is color coded blue and labeled **MEASUREMENT**. Use the red alignment mark on the 2 connectors to properly align them before connecting
5. On test lead set labeled CT X/S connect the test lead binding posts X1 X2, X3, X4 and XN to secondary of the current transformer X1, X2, X3, X4 and X5 (if less than 5 taps are available on the CT, then connect the test set secondary output binding posts X1, X2... to the correlating secondary of the current transformer with the EXCEPTION of connecting the test set secondary output binding Xn to the most external secondary of the current transformer. For Example on a 3 Tap CT Connect X1(test set) to X1(CT), X2(test set) to X2 (CT), and Xn (test set) to X3 (CT)
6. On test lead set labeled CT H/P connect the test lead primary binding posts H1 and H2 to CT primary bushings H1 and H2.Observe the polarity marks on the CT (H1 on the test set is polarity terminal).

WARNING

The MVCT produces high voltages and currents during the performance of tests. DO NOT TOUCH connector clips or test leads while the MVCT is performing a test.

7. Turn Power ON/OFF switch to ON
8. After the boot up, select the “Nameplate Information” menu by selecting



Name Plate navigation button.

9. Fill in nameplate information about the CT. At a minimum, the number of taps and secondary must be selected.



10. From the Home Screen select the “Winding Resistance” button
11. In the Winding Resistance test screen, selecting the Concurrent Mode of operation will allow the user to test multiple taps in parallel.



Figure 74 CT Winding Test Screen – Concurrent

12. Select the play button and a connection diagram will appear showing the proper connections for the MVCT to the CT

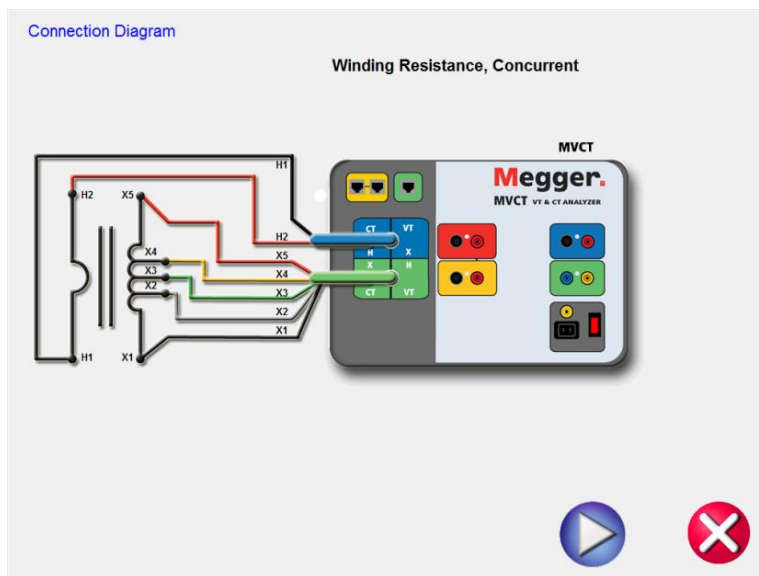


Figure 75 CT Winding Connection Diagram – Concurrent

13. Check all connections to ensure correctness

Hit Blue Play button to begin test.



14. The Winding Resistance test will begin.

- ⇒ Voltage (V): The MVCT displays the real time voltage readings of the secondary winding while the test is in progress.
- ⇒ Current (A): The MVCT the real time current readings for the secondary winding while the test is in progress.

15. At any point of time Test can be terminated by hitting the ABORT button at the top of the screen.

Tap	Current (A)	Voltage (V)
X1-X2	5.000	18.500
X1-X3	5.000	19.000
X1-X4	5.000	19.500
X1-X5	5.000	20.000
X2-X3	5.000	0.500
X2-X4	5.000	1.000
X2-X5	5.000	1.500
X3-X4	5.000	0.500
X3-X5	5.000	1.000
X4-X5	5.000	0.500

DC Current
5A

Figure 76 CT Winding Test ABORT

16. Upon completion of all tests, the results can be viewed in the test screen or in a test report.

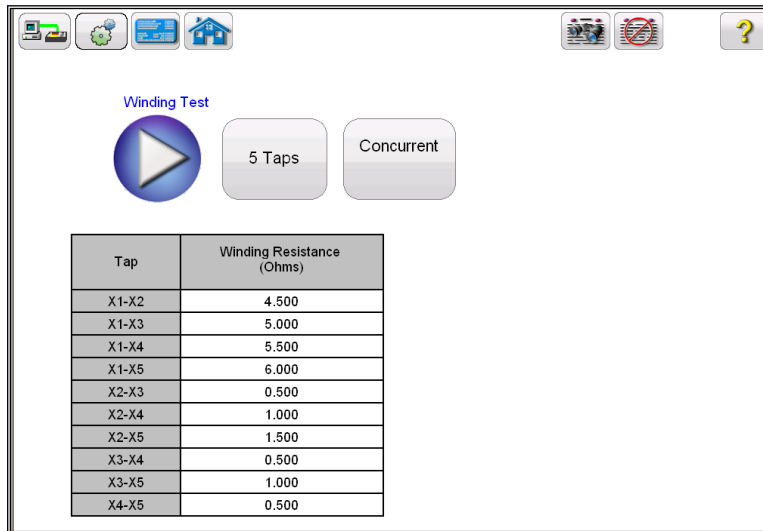


Figure 77 CT Winding Results - Concurrent

Winding resistance test is used to determine if the dc resistance of the CT secondary winding is within specification or not. A DC current is applied and voltage is measured to determine the winding resistance for the selected tap. After measurement winding resistance is displayed in digital format on the screen.

Note: A CT should be demagnetized after running the winding resistance test. Run a saturation test to demagnetize the CT at the completion of all winding resistance tests.

6.4.2 Method 2 – Non Concurrent or Testing a Single Tap

Refer to the safety instructions first before use of the equipment.

1. Verify the Power ON/OFF switch is OFF. Power the test set from a suitable source of power (95-125 or 195-265 V50/60 Hz).
2. Connect the ground wing nut to a suitable ground.

WARNING

There is always the possibility of voltages being induced at the terminals of a test specimen because of proximity to high voltage energized lines. A residual static voltage charge may also be present at these terminals. Ground each terminal to be tested with a safety ground stick, before making connections.

3. On test lead set labeled CT X/S connect the high voltage connector color coded green to the MVCT high voltage connector that is color coded green and labeled **SOURCE** Voltage. Use the red alignment marks on the 2 connectors to properly align them before connecting.
4. On test lead set labeled CT H/P Connect the high voltage connector color coded blue to the MVCT high voltage connector that is color coded blue and labeled **MEASUREMENT**. Use the red alignment mark on the 2 connectors to properly align them before connecting
5. On test lead set labeled CT X/S connect the test lead binding posts X1 and X5 to secondary of the current transformer on the desired tap. Observe the polarity marks on the CT (X1 on test set is polarity terminal).
6. On test lead set labeled CT H/P connect the test lead primary binding posts H1 and H2 to CT primary bushings H1 and H2. Observe the polarity marks on the CT (H1 on the test set is polarity terminal).

WARNING

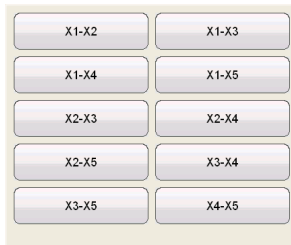
The MVCT produces high voltages and currents during the performance of tests. **DO NOT TOUCH** connector clips or test leads while the MVCT is performing a test.

7. Turn Power ON/OFF switch to ON
8. After boot up, in the Home Screen select the “Winding Resistance Test” button In the Winding Resistance test screen, deselect the Concurrent Mode of operation. This will allow the user to conduct a saturation test upon an individual tap

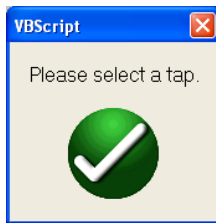


Figure 78 CT Winding Test Screen – Non Concurrent

9. Hit the Select Tap function button to select the appropriate tap to be tested



10. Select the tap configuration before hitting the PLAY button. If PLAY button is pressed before selecting the tap, following message will appear:



11. After selecting the appropriate tap, select the play button and a connection diagram will appear showing how to correctly connect the MVCT to the CT

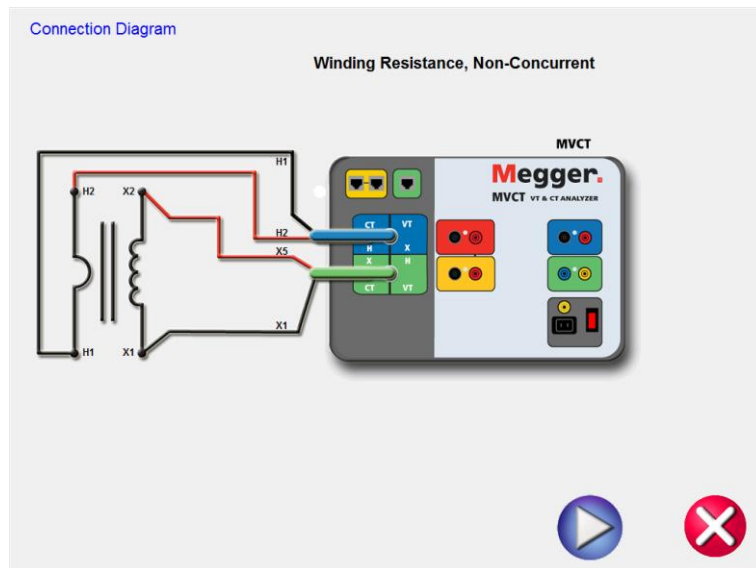


Figure 79 CT Winding Resistance Connection Diagram Non Concurrent

12. Check all connections to ensure correctness

13. Hit Blue Play button to begin test.



14. The Winding Resistance test will begin.

- ⇒ X Voltage (V): The MVCT displays the real time voltage readings of the secondary X winding while the test is in progress.
- ⇒ X Current (A): The MVCT the real time DC current readings for the secondary X winding while the test is in progress.

15. At any point of time Test can be terminated by hitting the ABORT button at the top of the screen...

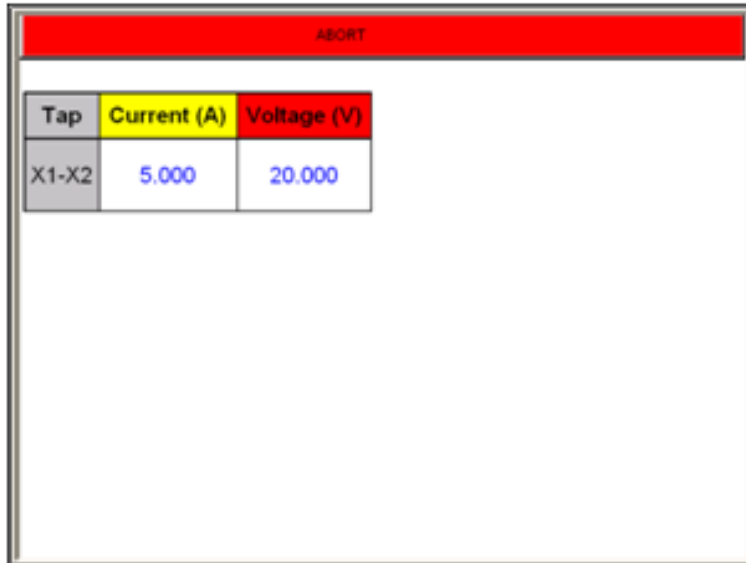


Figure 80 CT Winding Test Screen –Abort

16. Upon completion of all tests the results will be displayed in the test screen or in a test report.



Figure 81 CT Winding Results - Non Concurrent

Winding resistance test is used to determine if the dc resistance of the CT secondary winding is within specification or not. A DC current is applied and voltage is measured to determine the winding resistance for the selected tap. After measurement winding resistance is displayed in digital and analog format on the screen.

Note: A CT should be demagnetized after running the winding resistance test. Run a saturation test to demagnetize the CT at the completion of all winding resistance tests.

6.5 Insulation Test:

Refer to the safety instructions first before use of the equipment.

1. Verify the Power ON/OFF switch is OFF. Power the test set from a suitable source of power (95-125 or 195-265 V50/60 Hz).
2. Connect the ground wing nut to a suitable ground.

WARNING

There is always the possibility of voltages being induced at the terminals of a test specimen because of proximity to high voltage energized lines. A residual static voltage charge may also be present at these terminals. Ground each terminal to be tested with a safety ground stick, before making connections.

3. On test lead set labeled CT X/S connect the high voltage connector color coded green to the MVCT high voltage connector that is color coded green and labeled **SOURCE** Voltage. Use the red alignment marks on the 2 connectors to properly align them before connecting.
4. On test lead set labeled CT H/P Connect the high voltage connector color coded blue to the MVCT high voltage connector that is color coded blue and labeled **MEASUREMENT**. Use the red alignment mark on the 2 connectors to properly align them before connecting
5. On test lead set labeled CT X/S connect the test lead binding posts X1 and X5 to secondary of the current transformer on the desired tap. Observe the polarity marks on the CT (X1 on test set is polarity terminal).
6. On test lead set labeled CT H/P connect the test lead primary binding posts H1 and H2 to CT primary bushings H1 and H2. Observe the polarity marks on the CT (H1 on the test set is polarity terminal).

WARNING

The MVCT produces high voltages and currents during the performance of tests. DO NOT TOUCH connector clips or test leads while the MVCT is performing a test.

7. Turn Power ON/OFF switch to ON.
8. After boot up, in the Home Screen select the “Insulation Test” button
9. In the Insulation test screen, select the desired test level of either 500V or 1 KV by using the Voltage selection button

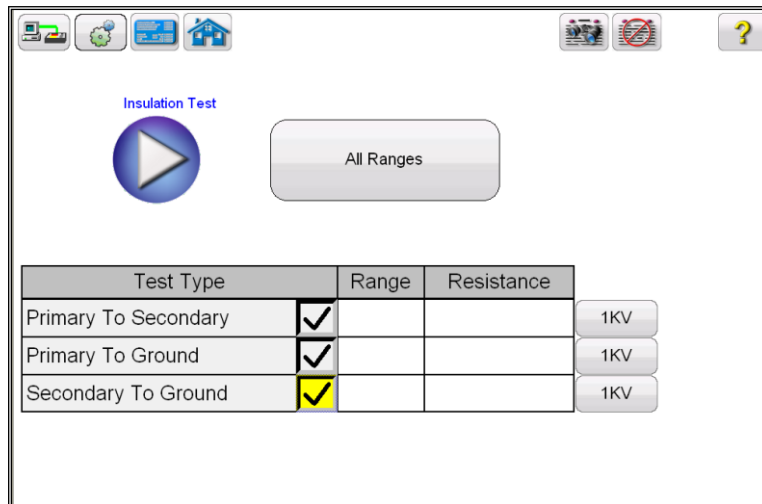


Figure 82 CT Insulation Test Screen

10. Select desired test by checking the adjacent check box next to the three available tests User can select one or any combination of the three test mode.
 - a) Primary to Secondary
 - b) Primary to Ground
 - c) Secondary to Ground
11. Select the play button and a connection diagram will appear showing how to correctly connect the MVCT to the CT

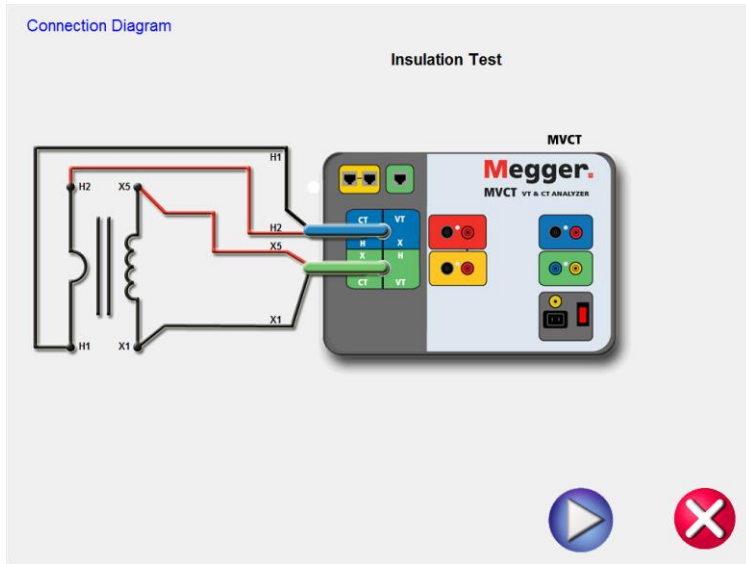


Figure 83 CT Insulation Test Connection Diagram

12. Check all connections to ensure correctness

13. Hit Blue Play button to begin test.



14. At any point of time Test can be terminated by hitting the ABORT button at the top of the screen.

Testing insulation
ABORT

TEST TYPE	RANGE	RESISTANCE	
PRIMARY TO SECONDARY	1KV	3.20G	1KV
PRIMARY TO GROUND			1KV
SECONDARY TO GROUND			1KV

Figure 84 CT Insulation Testing Screen

- Upon completion of all tests the results will be displayed in the test screen or in a test report.

Test Type	Range	Resistance	
Primary To Secondary	✓ 1KV	3.20G	1KV
Primary To Ground	✓ 1KV	3.21G	1KV
Secondary To Ground	✓ 1KV	3.22G	1KV

Figure 85 CT Insulation Test Results

6.6 Burden Test

Refer to the safety instructions first before use of the equipment.

- Verify the Power ON/OFF switch is OFF. Power the test set from a suitable source of power (95-125 or 195-265 V50/60 Hz).
- Connect the ground wing nut to a suitable ground.

WARNING

There is always the possibility of voltages being induced at the terminals of a test specimen because of proximity to high voltage energized lines. A residual static voltage charge may also be present at these terminals. Ground each terminal to be tested with a safety ground stick, before making connections.

- Disconnect the burden on de-energized CT.
Note: Refer to the Burden Test connection diagram below for more details.
- Connect the test set primary binding posts H1 and H2 to either side of the CT burden. and H2.
- On test lead set labeled CT X/S connect the high voltage connector color coded green to the MVCT high voltage connector that is color coded green and labeled **SOURCE** Voltage. Use the red alignment marks on the 2 connectors to properly align them before connecting.
- On test lead set labeled CT H/P Connect the high voltage connector color coded blue to the MVCT high voltage connector that is color coded blue and labeled **MEASUREMENT**. Use the red alignment mark on the 2 connectors to properly align them before connecting

7. On test lead set labeled CT X/S connect the test lead binding posts X1 and X5 to either side of the burden of the CT
8. On test lead set labeled CT H/P connect the test lead primary binding posts H1 and H2 to CT primary bushings H1 and H2. Observe the polarity marks on the CT (H1 on the test set is polarity terminal).
- 9.

WARNING

The MVCT produces high voltages and currents during the performance of tests. DO NOT TOUCH connector clips or test leads while the MVCT is performing a test.

10. Turn Power ON/OFF switch to ON.
11. After the boot up, in the Home Screen select the “Burden Test” button
12. In the Burden test screen, select the appropriate test current of either 1 Amp or 5 Amp based upon secondary current rating of the CT under test

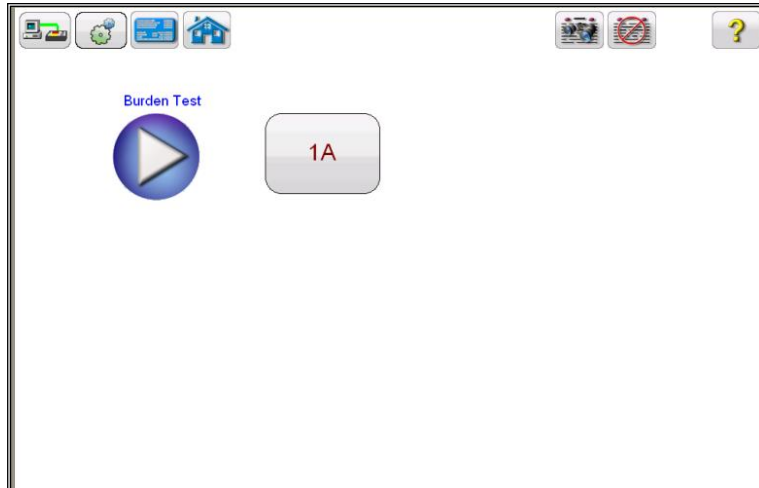


Figure 86 CT Burden Test Screen

13. Select the play button and a connection diagram will appear showing how to correctly connect the MVCT to the CT

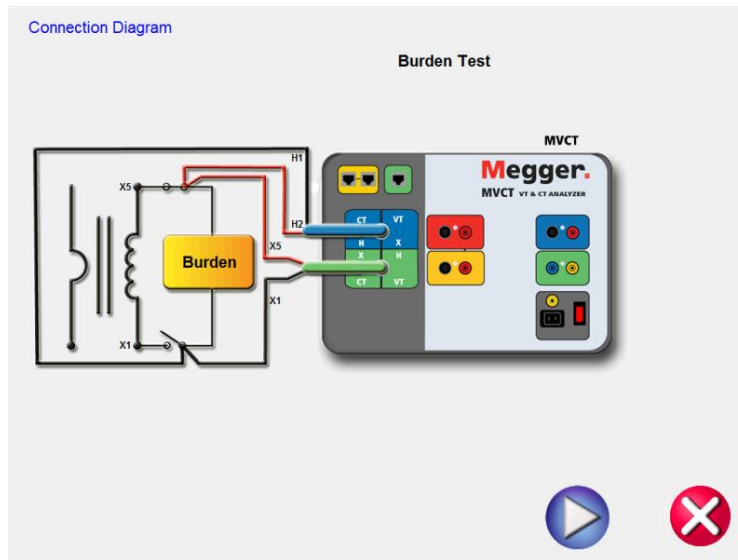


Figure 87 CT Burden Test Connection Diagram

14. Check all connections to ensure correctness

15. Hit Blue Play button to begin test.



16. The Burden test will begin.

Voltage (V): The MVCT displays the real time voltage readings of the burden while the test is in progress.

Current (A): The MVCT the real time current readings for the burden while the test is in progress.

17. At any point of time Test can be terminated by hitting the ABORT button at the top of the screen.

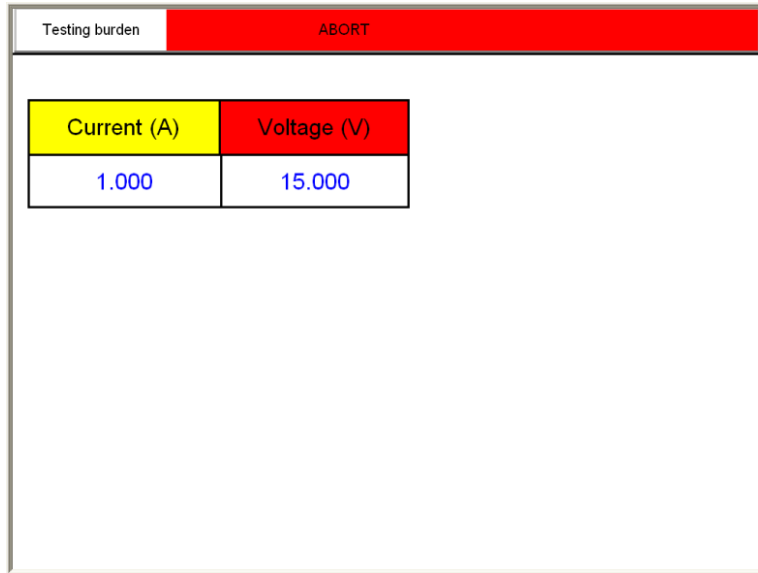


Figure 88 CT Burden Test Abort

18. Upon completion of all tests the results will be displayed in the test screen or in a test report.

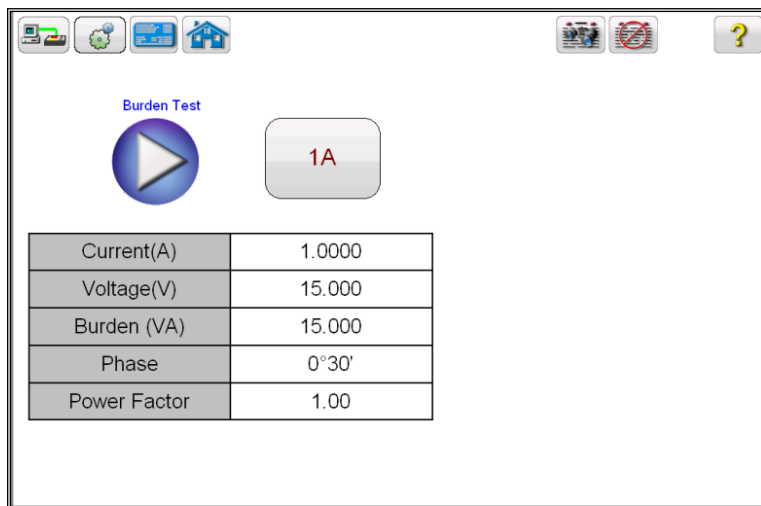


Figure 89 CT Burden Test Results Screen

Burden test is performed to verify that CT under test is capable of supplying a known current into a know burden while maintaining its stated accuracy. A burden test is typically performed at full rated secondary current value. Burdens are typically expressed in VA

X Current (A): It displays the applied current (user selected 1A or 5A) to the burden of the CT.

X Voltage (V): It displays the real time measured voltage across the burden of the CT.

Burden VA: Displays the burden on the CT in VA, after the completion of test.

Phase angle: Displays phase angle between X Current and X Voltage

PF: Displays ratio of real power to apparent power.

6.7 Manual Test

Refer to the safety instructions first before use of the equipment.

1. Verify the Power ON/OFF switch is OFF. Power the test set from a suitable source of power (95-125 or 195-265 V50/60 Hz).
2. Connect the ground wing nut to a suitable ground.

WARNING

There is always the possibility of voltages being induced at the terminals of a test specimen because of proximity to high voltage energized lines. A residual static voltage charge may also be present at these terminals. Ground each terminal to be tested with a safety ground stick, before making connections.

3. On test lead set labeled CT X/S connect the high voltage connector color coded green to the MVCT high voltage connector that is color coded green and labeled **SOURCE** Voltage. Use the red alignment marks on the 2 connectors to properly align them before connecting.
4. On test lead set labeled CT H/P Connect the high voltage connector color coded blue to the MVCT high voltage connector that is color coded blue and labeled **MEASUREMENT**. Use the red alignment mark on the 2 connectors to properly align them before connecting
5. On test lead set labeled CT X/S connect the test lead binding posts X1 and X5 to secondary of the current transformer on the desired tap. Observe the polarity marks on the CT (X1 on test set is polarity terminal).
6. On test lead set labeled CT H/P connect the test lead primary binding posts H1 and H2 to CT primary bushings H1 and H2. Observe the polarity marks on the CT (H1 on the test set is polarity terminal).

WARNING

The MVCT produces high voltages and currents during the performance of tests. DO NOT TOUCH connector clips or test leads while the MVCT is performing a test.

7. Turn Power ON/OFF switch to ON.



8. After the boot up, in the Home Screen select the "Manual Test" button

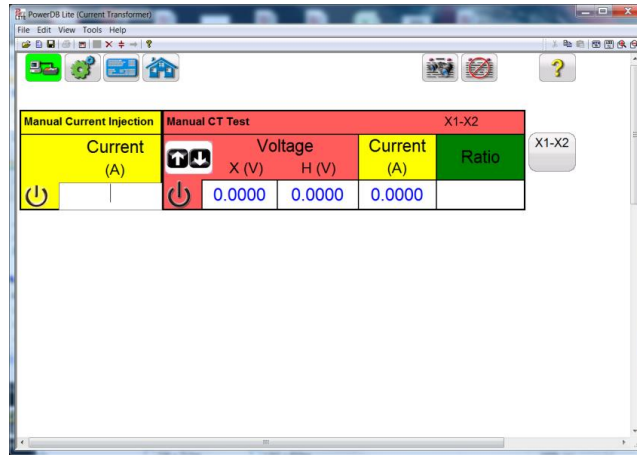

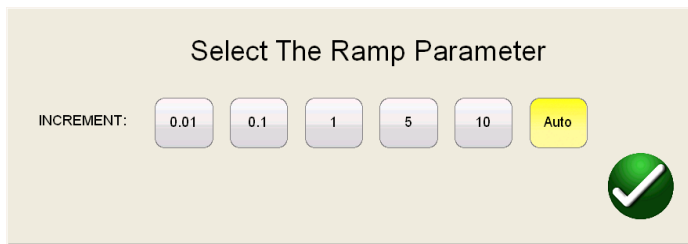


Figure 90 CT Manual Test Screen

9. In the Manual Test screen, by selecting the Ramp adjustment button  , the user may select the amount of increment the voltage is either decreased or increased by turning the knob on the STVI.



10. After making this selection, select the appropriate tap to be tested,
11. Begin the test by selecting the blue play button.



A connection diagram will appear showing the correct connects

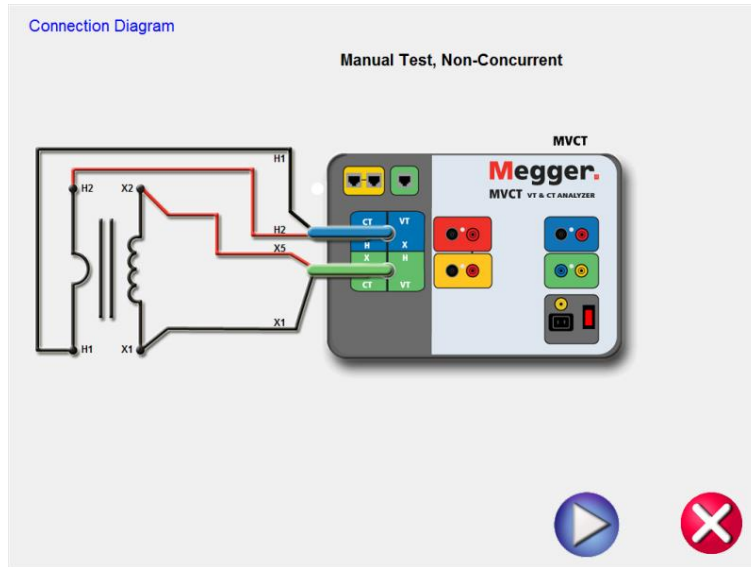


Figure 91 CT Manual Test Connection Diagram

12. Ensure the MVCT is properly connected.

13. Begin the test by selecting the Blue play button.



14. The MVCT will display:

Secondary (X) Voltage: The applied secondary test voltage is displayed on the screen in digital readout form.

Primary (H) Voltage: The measured primary voltage is displayed on the screen in digital readout form.

Secondary(X) Current: The secondary current is displayed for user reference to monitor while performing ratio and saturation tests.

15. Ramp the voltage up and down by turning the knob on the integrated display or selecting the up/down arrows on a PC

16. At the desired voltage level select the Record Button and the secondary voltage and current levels will be stored and then this point will be graphed into a log-log format.

17. This Manual Test allows the user to manually create saturation curves.

6.8 Demagnetization

Refer to the safety instructions first before use of the equipment.

1. Verify the Power ON/OFF switch is OFF. Power the test set from a suitable source of power (95-125 or 195-265 V50/60 Hz).
2. Connect the ground wing nut to a suitable ground.

WARNING

There is always the possibility of voltages being induced at the terminals of a test specimen because of proximity to high voltage energized lines. A residual static voltage charge may also be present at these terminals. Ground each terminal to be tested with a safety ground stick, before making connections.

- 3 On test lead set labeled CT X/S connect the high voltage connector color coded green to the MVCT high voltage connector that is color coded green and labeled **SOURCE** Voltage. Use the red alignment marks on the 2 connectors to properly align them before connecting.
- 4 On test lead set labeled CT H/P Connect the high voltage connector color coded blue to the MVCT high voltage connector that is color coded blue and labeled **MEASUREMENT**. Use the red alignment mark on the 2 connectors to properly align them before connecting
- 5 On test lead set labeled CT X/S connect the test lead binding posts X1 and X5 to secondary of the current transformer on the desired tap. Observe the polarity marks on the CT (X1 on test set is polarity terminal).
- 6 On test lead set labeled CT H/P connect the test lead primary binding posts H1 and H2 to CT primary bushings H1 and H2. Observe the polarity marks on the CT (H1 on the test set is polarity terminal).

WARNING

The MVCT produces high voltages and currents during the performance of tests. DO NOT TOUCH connector clips or test leads while the MVCT is performing a test.

- 7 Turn Power ON/OFF switch to ON.



- 8 After the boot up, in the Home Screen select the “Demagnetization” button
- 9 A connection diagram will appear showing how to properly connect the MVCT to the CT.

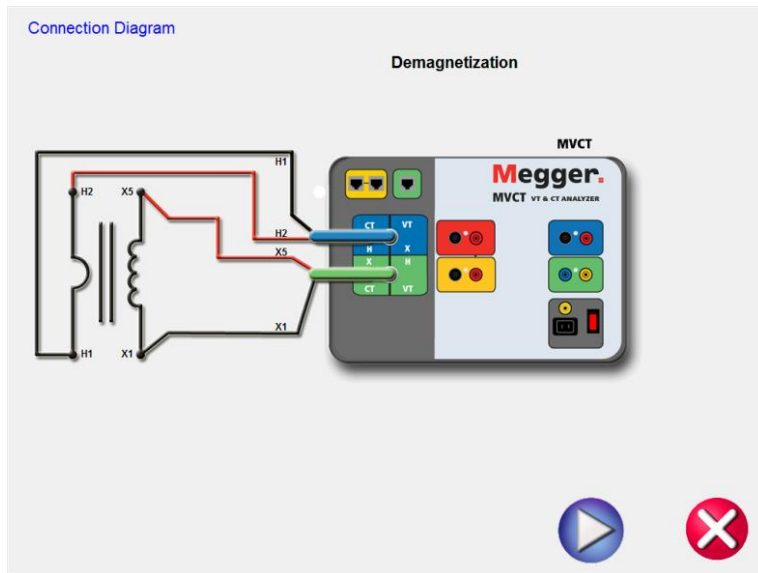


Figure 92 CT Demagnetization Connection Diagram

- 10 Confirming all the connections are correct,
- 11 Continue with demagnetizing the CT by selecting the Blue Play button CHECK. The red X will cancel the operation.
- 12 After selecting to continue the operation, the user will be advised that the CT is being demagnetized

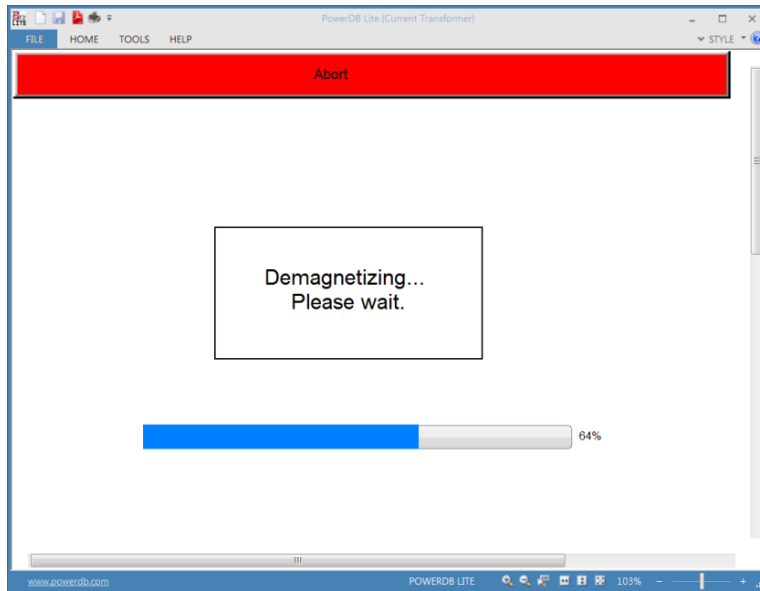


Figure 93 CT Demagnetizing Process Screen

- 13 Upon completion, the user will be returned to the Home Screen and notified the demagnetization process is complete.

6.9 Self Test

Refer to the safety instructions first before use of the equipment.

1. Verify the Power ON/OFF switch is OFF. Power the test set from a suitable source of power (95-125 or 195-265 V50/60 Hz).
2. Connect the ground wing nut to a suitable ground.

- WARNING**

There is always the possibility of voltages being induced at the terminals of a test specimen because of proximity to high voltage energized lines. A residual static voltage charge may also be present at these terminals. Ground each terminal to be tested with a safety ground stick, before making connections.
3. On test lead set labeled CT H/P Connect the high voltage connector color coded blue to the MVCT high voltage connector that is color coded blue and labeled **MEASUREMENT**. Use the red alignment mark on the 2 connectors to properly align them before connecting
 4. On test lead set labeled CT X/S, using supplied jumpers connect the test lead binding posts X1 and X5 to binding posts H1 and H2 of the test lead set labeled CT H/P

WARNING

The MVCT produces high voltages and currents during the performance of tests. DO NOT TOUCH connector clips or test leads while the MVCT is performing a test.

6. Turn Power ON/OFF switch to ON.



After the boot up, in the Home Screen select the “Self Diagnostic” button

7. The following connection diagram will appear. Ensure the MVCT is connected properly.

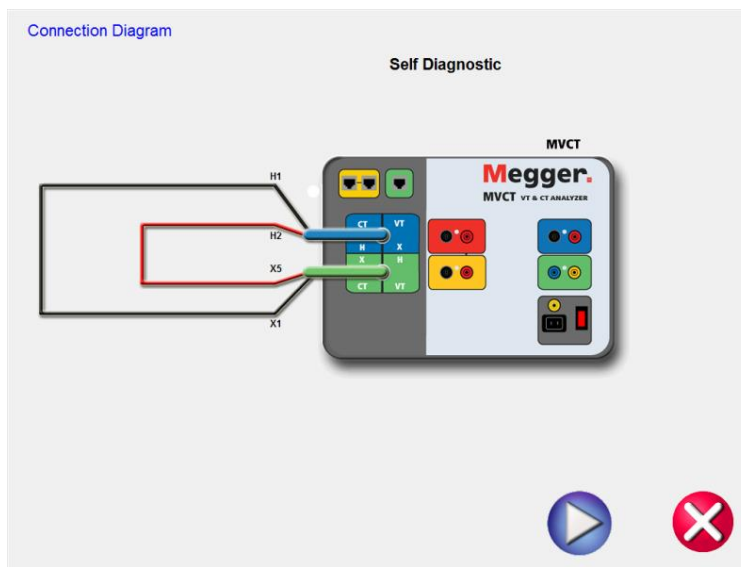


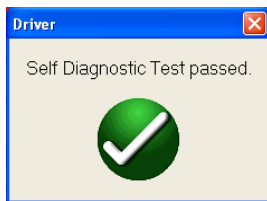
Figure 94 CT Self Diagnostic Connection Diagram

8. During the Self Test, Secondary Current, Secondary Voltage and Primary Voltage will be displayed

Self testing		ABORT	
Current (A)	Voltage (V)	H Voltage(V)	
0.100	0.300	0.300	

Figure 95 CT Self Diagnostic Test Screen

9. After the unit has checked the voltage and current generators and meters are working properly, the user will be advised the unit has passed or failed the test



7.0 Testing VT's with MVCT

7.1 Running a Complete Test of VT and Test Plan Creation

Refer to the safety instructions first before use of the equipment.

1. Verify the Power ON/OFF switch is OFF. Power the test set from a suitable source of power (95-265 V50/60 Hz).
2. Connect the ground wing nut to a suitable ground.

WARNING

There is always the possibility of voltages being induced at the terminals of a test specimen because of proximity to high voltage energized lines. A residual static voltage charge may also be present at these terminals. Ground each terminal to be tested with a safety ground stick. before making connections.

WARNING

The MVCT produces high voltages and currents during the performance of tests. DO NOT TOUCH connector clips or test leads while the MVCT is performing a test.

3. Turn Power ON/OFF switch to ON.
4. After the boot up, set the testing mode to VT and select the “Nameplate Information” menu by selecting



Name Plate navigation button.

5. Fill in nameplate information about the VT. At a minimum, the number VA rating and the secondary voltage of the VT must be entered
6. In the Home Screen, select the Run All Tests button. Within the Run All Test screen select all of the tests by placing a check in the adjacent box

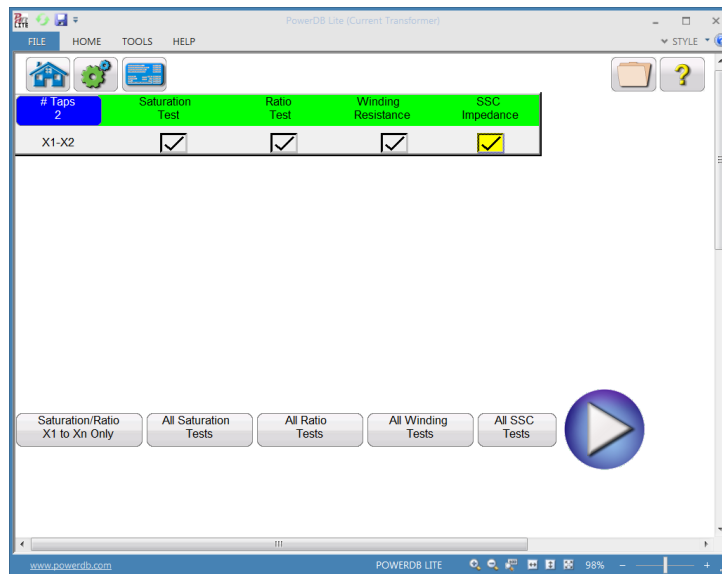


Figure 96 VT Test Plan Screen

7. Select the individual taps for saturation testing by placing a check in the corresponding



box. Or select all taps by selecting the corresponding to all taps.

8. Select the individual taps for ratio testing by placing a check in the corresponding



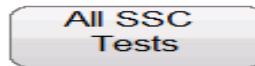
box. Or select all taps by selecting the corresponding to all taps.

9. Select the individual taps for Winding Res testing by placing a check in the corresponding



box. Or select all taps by selecting the corresponding to all taps.

10. Select the individual taps for Short Circuit Impedance testing by placing a check in the corresponding



box. Or select all taps by selecting the corresponding to all taps.

11. At this point, this test file could be saved, opened at a later date , and ran.

12. It can also be ran at this time by selecting the Blue Play button



13. A connection diagram will appear showing how to properly connect the MVCT to the VT

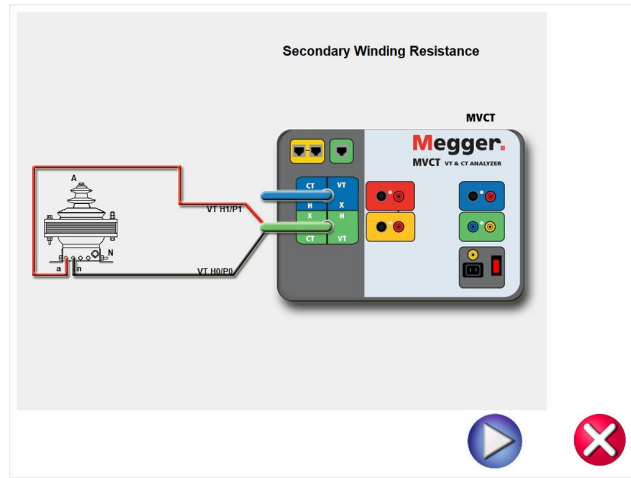


Figure 97 VT Connection Diagram for Winding Resistance

14. Continue the test by selecting the Blue Play button



15. At any point of time Test can be terminated by hitting the ABORT button at the top of any testing screen.

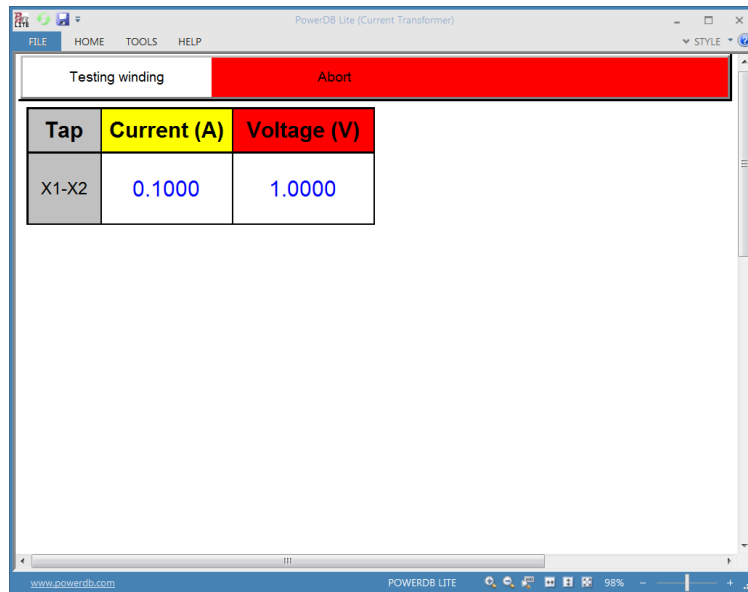


Figure 98 VT Winding Resistance Abort

16. Upon completion of Winding Resistance Test, the MVCT will automatically demagnetize the VT

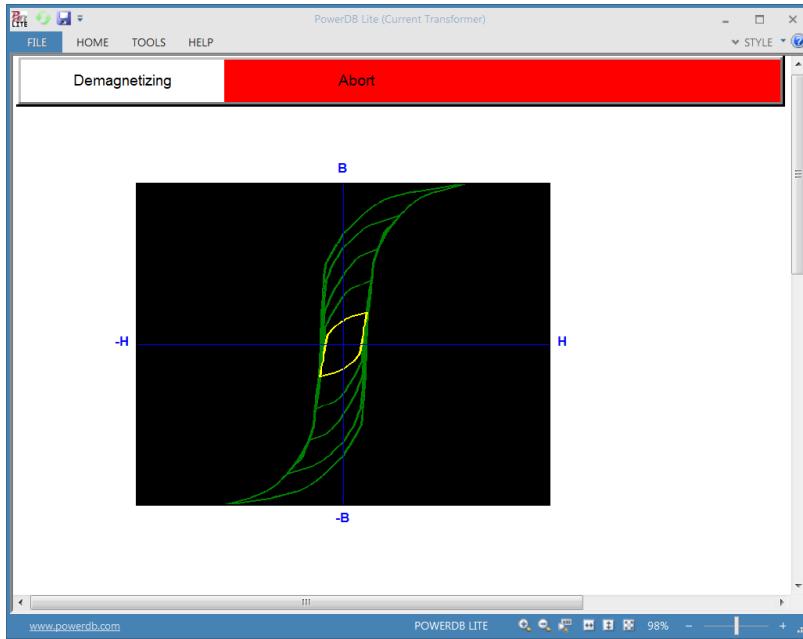


Figure 99 VT Demagnetization

17. Upon completion of demagnetization the MVCT will then perform an excitation/saturation test on the VT

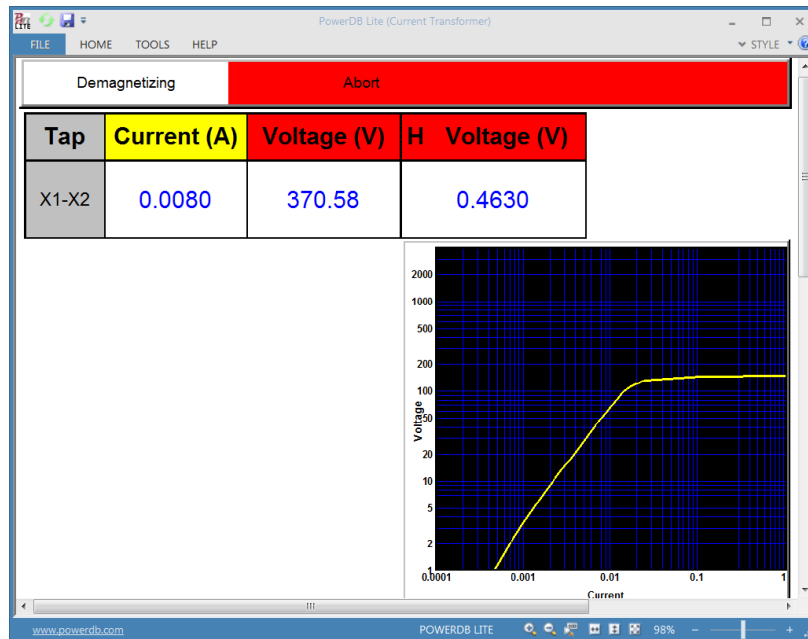


Figure 100 VT Saturation/Excitation Test

18. Upon completion of the excitation test, the MVCT will stop and display a connection diagram for the Secondary Short Circuit Impedance test

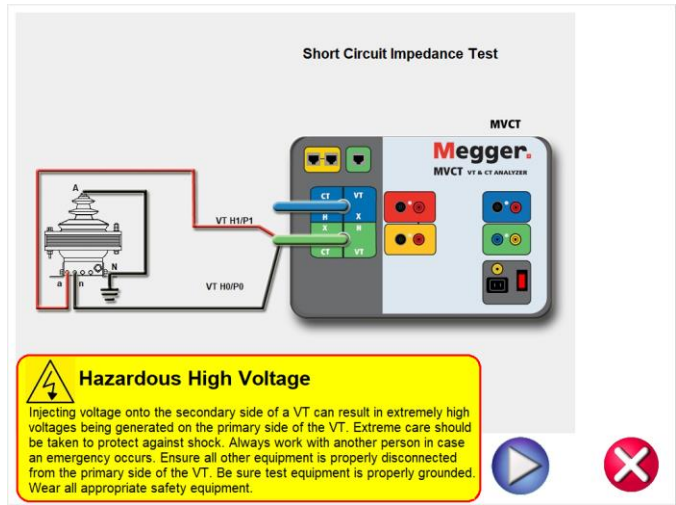


Figure 101 VT Short Circuit Impedance Connection Diagram

- 19 Follow the connection diagram and ensure the MVCT is properly connected for this test.
- 20 Select the Blue Play Button to continue the test



- 21 After completion of the Impedance test, the MVCT will display the connection diagram for the Ratio Test

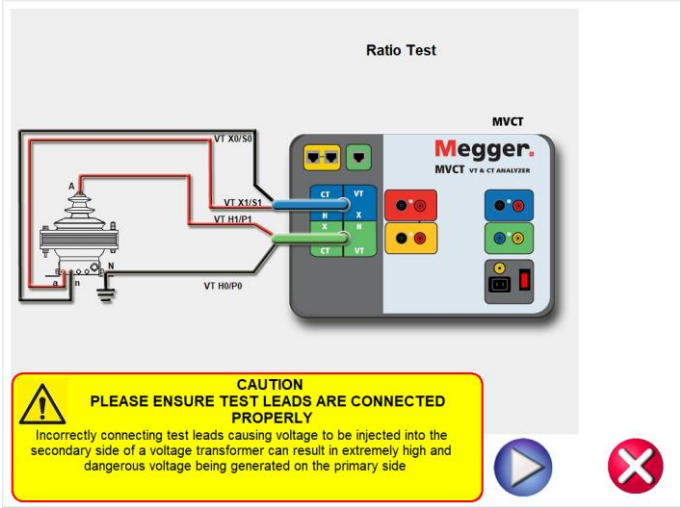


Figure 102 VT Ratio Test Connection Diagram

- 22 Follow the connection diagram and ensure the MVCT is properly connected for this test

25 Select the Blue Play Button to continue the test



26 After completion of the ratio test, the MVCT will take all the measurements and build a test report. This test report will be automatically displayed.

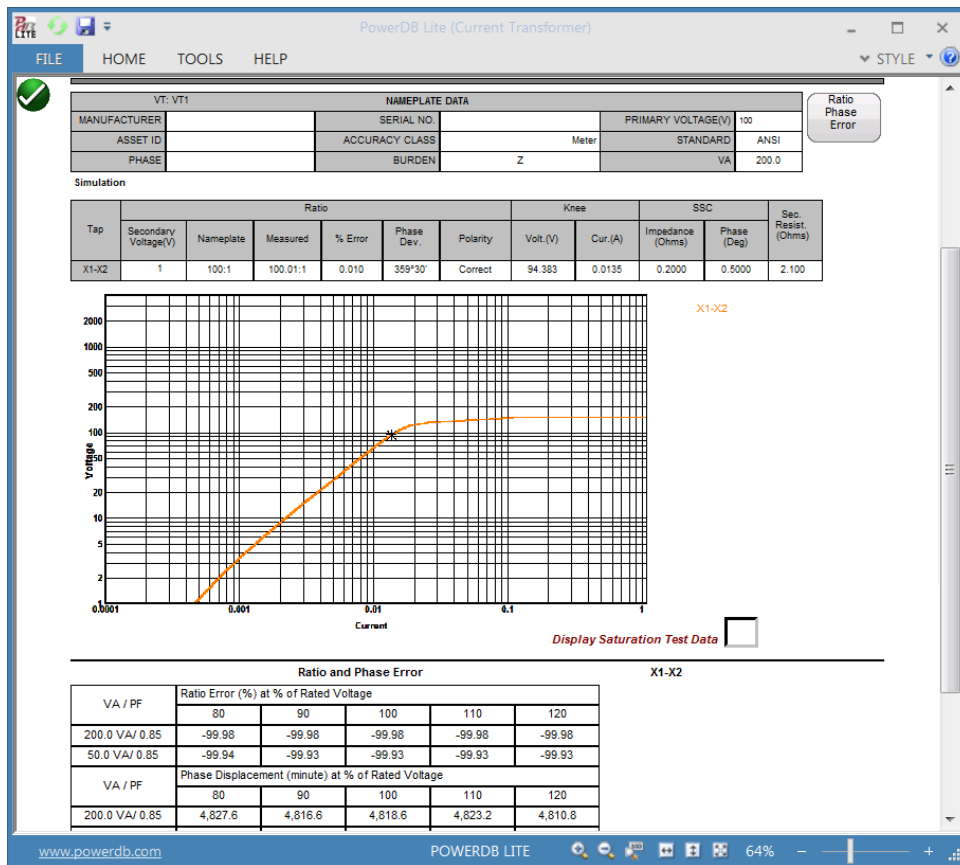


Figure 103 Sample VT Test Report

7.2 Testing VT Ratio and Phase

1. Refer to the safety instructions first before use of the equipment.
2. Verify the Power ON/OFF switch is OFF. Power the test set from a suitable source of power (95-125 or 195-265 V50/60 Hz).
3. Connect the ground wing nut to a suitable ground.


WARNING

There is always the possibility of voltages being induced at the terminals of a test specimen because of proximity to high voltage energized lines. A residual static voltage charge may also be present at these terminals. Ground each terminal to be tested with a safety ground stick, before making connections.

- 4 On test lead set labeled VT H/P connect the high voltage connector color coded green to the MVCT high voltage connector that is color coded green and labeled **SOURCE** Voltage. Use the red alignment marks on the 2 connectors to properly align them before connecting.
- 5 On test lead set labeled VT X/S Connect the high voltage connector color coded blue to the MVCT high voltage connector that is color coded blue and labeled **MEASUREMENT**. Use the red alignment mark on the 2 connectors to properly align them before connecting
- 6 On test lead set labeled VT H/P connect the test lead binding posts H0 and H1 to primary of the voltage transformer on the H0 and H1 terminals. Observe the polarity marks on the VT (H0 on test set is polarity terminal).
- 7 On test lead set labeled VT X/S connect the test lead binding posts X0 and X1 to VT secondary terminals X0 and X1. Observe the polarity marks on the VT (X0 on the test set is polarity terminal).

WARNING

The MVCT produces high voltages and currents during the performance of tests. DO NOT TOUCH connector clips or test leads while the MVCT is performing a test.

- 8 Turn Power ON/OFF switch to ON.
- 9 After the boot up, put the MVCT in VT Testing Mode by selecting the VT button at the top of the home screen.
- 10 After the VT mode is selected in the Home Screen select the "Ratio Test" button .

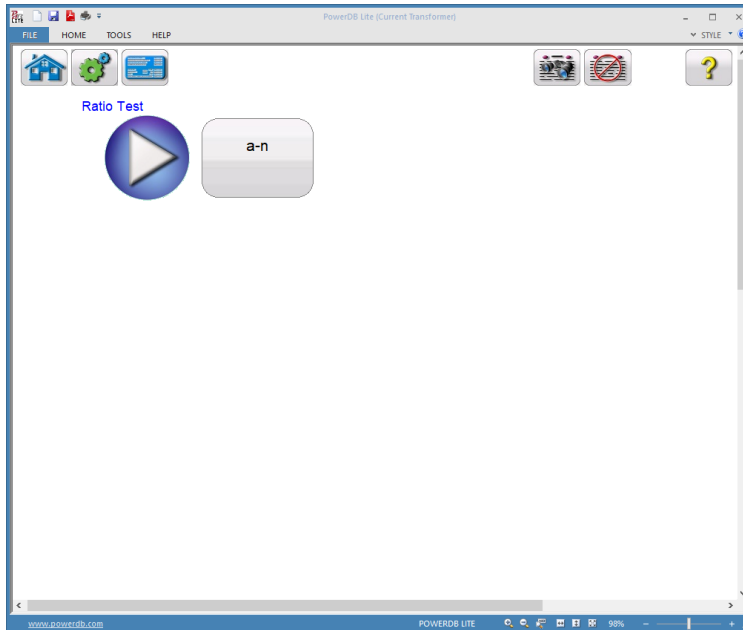


Figure 104 VT Ratio Test Screen

11 , Select the play button and a connection diagram will appear showing how to correctly connect the MVCT to the VT

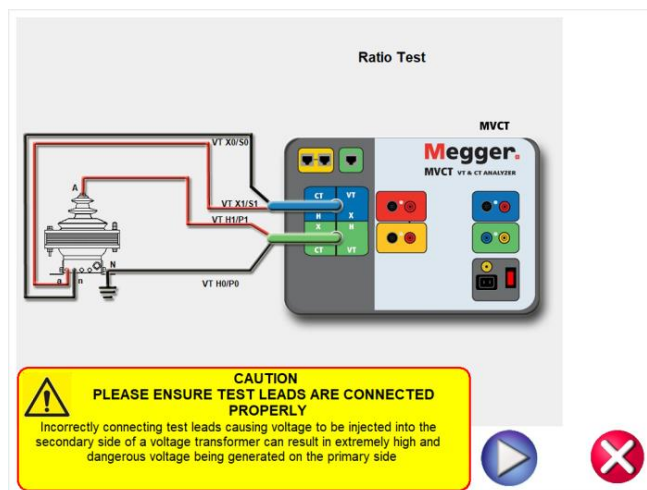


Figure 105 VT Ratio Test Connection Diagram

12 Check all connections to ensure correctness

- 13 Hit Blue Play button.



- 14 Hit Blue Play button to begin test.



- 15 The Ratio test will begin.

H Current (A): The MVCT the real time current readings for the primary H winding while the test is in progress.

H Voltage (V): The MVCT displays the real time voltage readings of the primary H winding while the test is in progress.

X Voltage (V): The MVCT the real time voltage readings of the secondary X winding while the test is in progress.

- 16 At any point of time Test can be terminated by hitting the ABORT button at the top of the screen.

Tap	Current (A)	Voltage (V)	X Voltage (V)
X1-X2	0.0064	36.323	0.3596

Figure 106 VT Ratio Testing Screen

- 17 Upon completion of all test the results will be displayed in the test screen or they can be displayed in a test report.

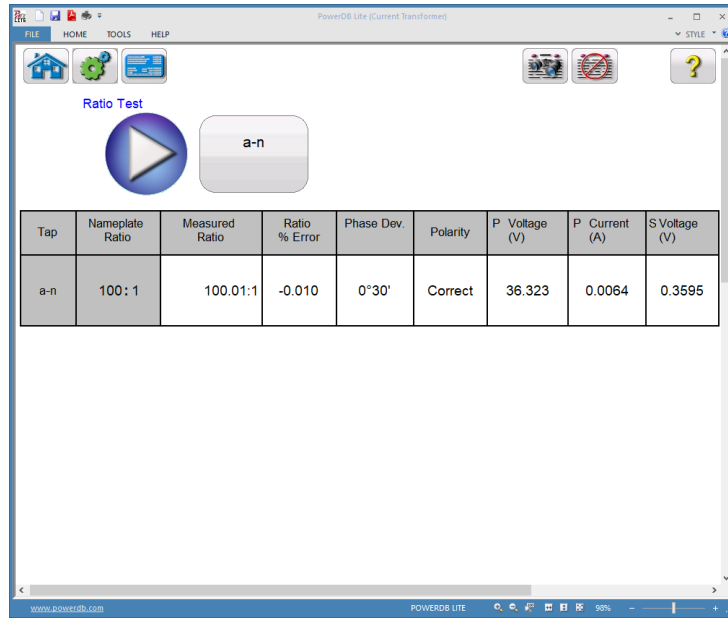


Figure 107 VT Ratio Test Results

7.3 Testing Voltage Transformer – Saturation/Excitation Test

Refer to the safety instructions first before use of the equipment.

1. Verify the Power ON/OFF switch is OFF. Power the test set from a suitable source of power (95-125 or 195-265 V50/60 Hz).
2. Connect the ground wing nut to a suitable ground.

WARNING

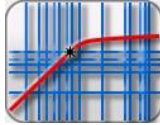
There is always the possibility of voltages being induced at the terminals of a test specimen because of proximity to high voltage energized lines. A residual static voltage charge may also be present at these terminals. Ground each terminal to be tested with a safety ground stick. before making connections.

3. Connect the test set secondary output binding posts X1 and X5 to secondary of the current transformer on the desired tap. Observe the polarity marks on the VT (X1 on test set is polarity terminal).

WARNING

The MVCT produces high voltages and currents during the performance of tests. DO NOT TOUCH connector clips or test leads while the MVCT is performing a test.

4. Turn Power ON/OFF switch to ON.
5. After the boot up, in the Home Screen, select the VT button at the top of the screen to put the MVCT in voltage transformer testing mode.



6. Select the "Saturation Test" button . This will bring the user to the Saturation/Excitation test screen

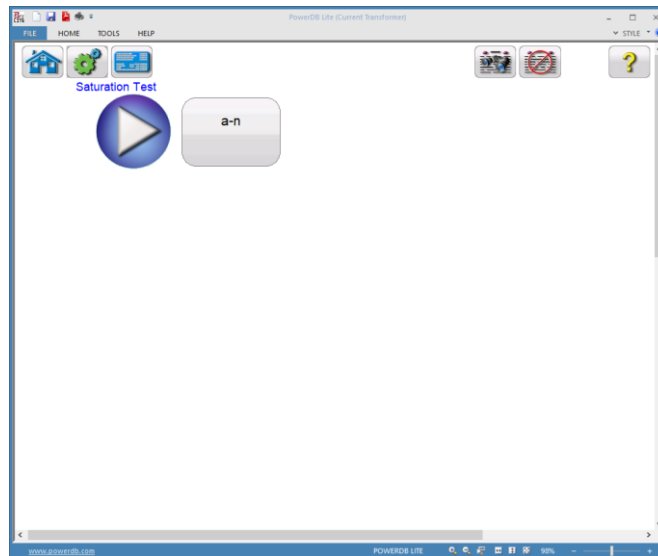


Figure 108 VT Saturation Test Screen

7. Select the blue play button and a connection diagram will appear showing how to correctly connect the MVCT to the VT

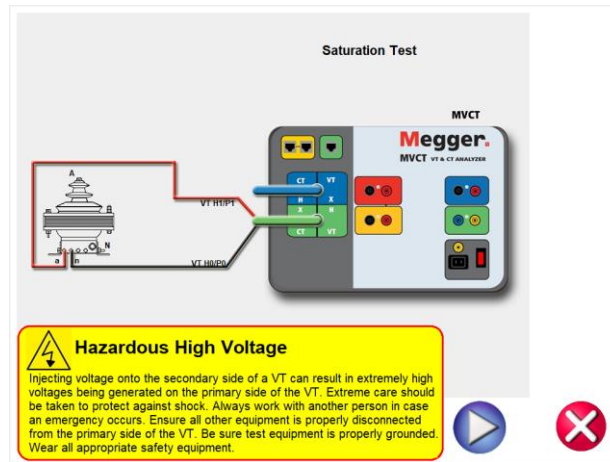


Figure 109 VT Saturation Connection Diagram

8. Check all connections to ensure correctness



9. Hit Blue Play button to begin test.
10. The saturation will begin and the test voltage and current will be displayed
 - ⇒ X Current (A): The MVCT the real time current readings for the secondary winding while the test is in progress.
 - ⇒ X Voltage (V): The MVCT displays the real time voltage readings of the secondary winding while the test is in progress.
 - ⇒ Saturation Curve: The excitation curve is Log-Log curve with secondary current on X coordinate and secondary voltage on Y coordinate. The Saturation curve will be graphed in the chart in the right hand corner of the screen in real time as data is accumulated.
11. At any point of time Test can be terminated by hitting the ABORT button at the top of the screen.

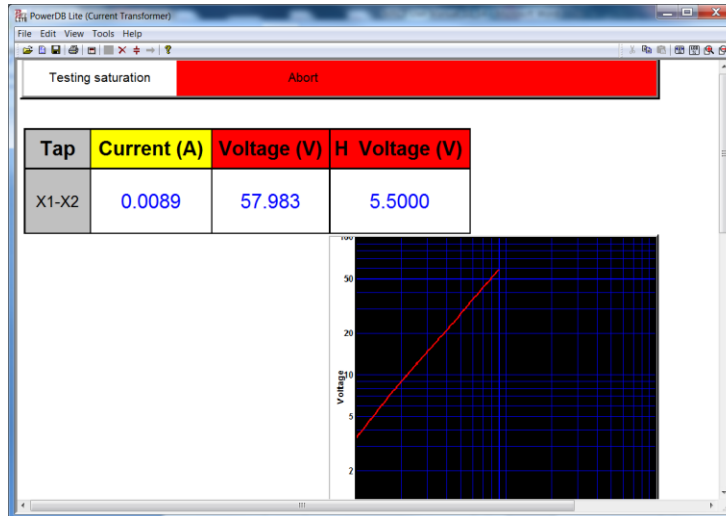


Figure 110 VT Saturation Test Screen

12. Upon completion of test the results will be displayed in the test screen or it can be displayed



in a test report by selecting the view report button

7.4 Testing Voltage Transformer Winding Resistance :

Refer to the safety instructions first before use of the equipment.

1. Verify the Power ON/OFF switch is OFF. Power the test set from a suitable source of power (95-125 or 195-265 V50/60 Hz).
2. Connect the ground wing nut to a suitable ground.

WARNING

There is always the possibility of voltages being induced at the terminals of a test specimen because of proximity to high voltage energized lines. A residual static voltage charge may also be present at these terminals. Ground each terminal to be tested with a safety ground stick, before making connections.

3. On test lead set labeled VT H/P connect the high voltage connector color coded green to the MVCT high voltage connector that is color coded green and labeled **SOURCE** Voltage. Use the red alignment marks on the 2 connectors to properly align them before connecting.

4. On test lead set labeled VT X/S Connect the high voltage connector color coded blue to the MVCT high voltage connector that is color coded blue and labeled **MEASUREMENT**. Use the red alignment mark on the 2 connectors to properly align them before connecting
5. On test lead set labeled VT H/P connect the test lead binding posts H0 and H1 to secondary of the voltage transformer on the X0 and X1 terminals. Observe the polarity marks on the VT (H0 on test set is polarity terminal).
6. On test lead set labeled VT X/S connect the test lead binding posts X0 and X1 to VT secondary terminals H0 and H1. Observe the polarity marks on the VT (X0 on the test set is polarity terminal).

WARNING

The MVCT produces high voltages and currents during the performance of tests. DO NOT TOUCH connector clips or test leads while the MVCT is performing a test.

7. Turn Power ON/OFF switch to ON
8. After boot up, in the Home Screen set the MVCT to VT Testing mode and select the “Winding Resistance Test” button.

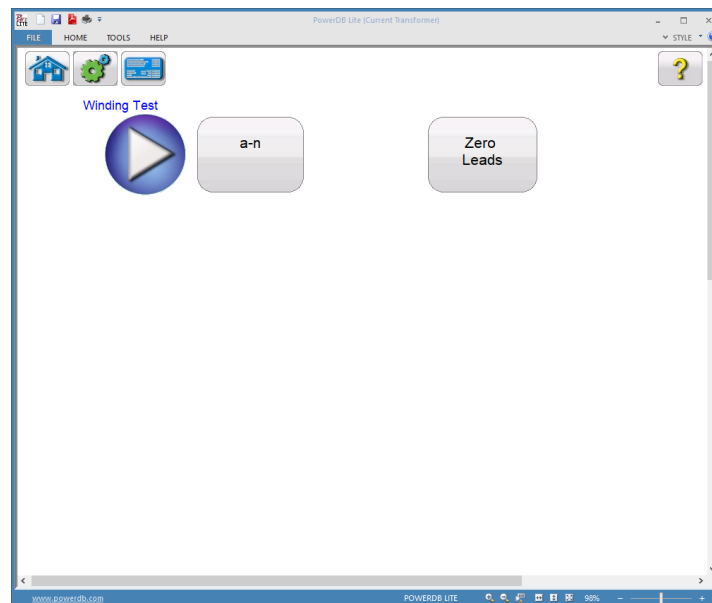


Figure 111 VT Winding Test Screen

ABORT		
Tap	Current (A)	Voltage (V)
X1-X2	5.000	20.000

Figure 113 VT Winding Test Screen –Abort

14. Upon completion of all tests the results will be displayed in the test screen or in a test report.

Tap	Winding Resistance (Ohms)
a-n	2.103

Figure 114 VT Winding Results

7.5 Testing Voltage Transformer: Secondary Short Circuit Impedance

Refer to the safety instructions first before use of the equipment.

1. Verify the Power ON/OFF switch is OFF. Power the test set from a suitable source of power (95-125 or 195-265 V50/60 Hz).
2. Connect the ground wing nut to a suitable ground.

WARNING

There is always the possibility of voltages being induced at the terminals of a test specimen because of proximity to high voltage energized lines. A residual static voltage charge may also be present at these terminals. Ground each terminal to be tested with a safety ground stick, before making connections.

WARNING

The MVCT produces high voltages and currents during the performance of tests. DO NOT TOUCH connector clips or test leads while the MVCT is performing a test.

3. Turn Power ON/OFF switch to ON.
4. After boot up, in the Home Screen put the MVCT in voltage transformer testing mode by selecting the VT button.
5. Select the "Secondary Short Circuit Impedance" button In the VT section of the Home Screen. This will activate the impedance test screen

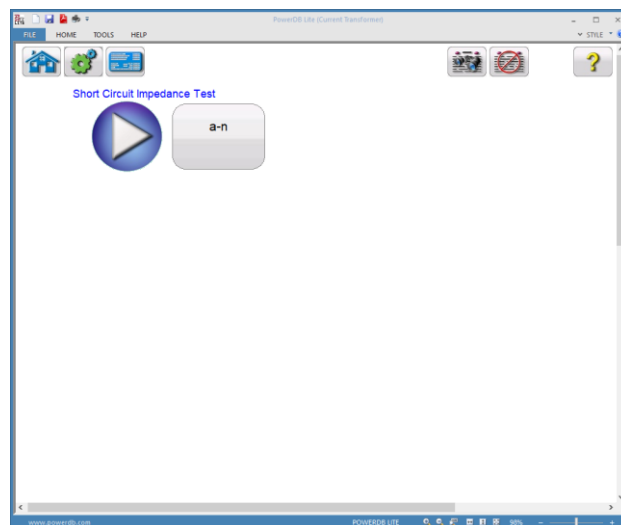


Figure 115 VT Secondary Short Circuit Impedance Test Screen

6. Select the play button and a connection diagram will appear showing how to correctly connect the MVCT to the VT

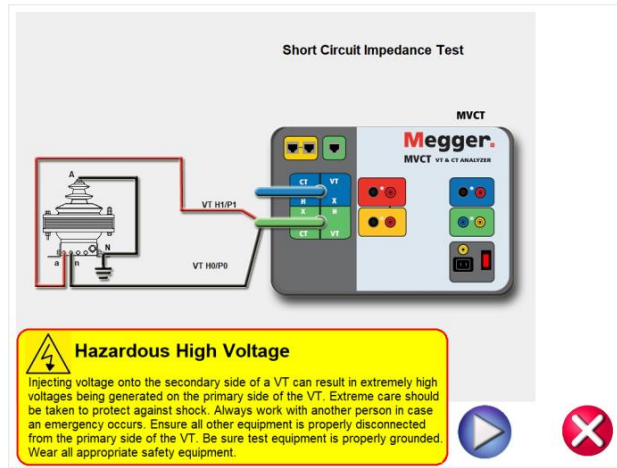


Figure 116 VT Short Circuit Impedance Connection Diagram

7. Check all connections to ensure correctness

8. Hit Blue Play button to begin test.



9. The Short Circuit Impedance test will begin.

- ⇒ X Current (A): The MVCT the real time DC current readings for the secondary X winding while the test is in progress.
- ⇒ Voltage (V): The MVCT displays the real time voltage readings of the secondary X winding while the test is in progress.
- ⇒

10. At any point of time Test can be terminated by hitting the ABORT button at the top of the screen...

ABORT		
Tap	Current (A)	Voltage (V)
X1-X2	5.000	20.000

DC Current
5A

Figure 117 VT Short Circuit Impedance -Abort

11. Upon completion of test the results will be displayed in the test screen or in a test report if desired.

Tap	Impedance (Ohms)	Phase (Degree)
a-n	0.224	0.500

Figure 118 VT Short Circuit Impedance Results

Short Circuit Impedance test is used to determine the impedance of the VT secondary and primary windings. After measurement the impedance is calculated and displayed on the screen.

These values are used along with additional test values to estimate the VT performance at rated line voltage.

7.6 Testing Voltage Transformer : Demagnetization

Refer to the safety instructions first before use of the equipment.

1. Verify the Power ON/OFF switch is OFF. Power the test set from a suitable source of power (95-125 or 195-265 V50/60 Hz).
2. Connect the ground wing nut to a suitable ground.

WARNING

There is always the possibility of voltages being induced at the terminals of a test specimen because of proximity to high voltage energized lines. A residual static voltage charge may also be present at these terminals. Ground each terminal to be tested with a safety ground stick, before making connections.

3. Connect the test set secondary output **SOURCE** binding posts **X1S** and **X5S** to the **desired** secondary terminals of the voltage transformer.
4. . Observe the polarity marks on the VT (X1 on test set is polarity terminal).

WARNING

The MVCT produces high voltages and currents during the performance of tests. **DO NOT TOUCH** connector clips or test leads while the MVCT is performing a test.

5. Turn Power ON/OFF switch to ON.
6. After boot up, in the Home Screen put the MVCT in voltage transformer testing mode by selecting the VT button.

7. Select the “Demagnetization” button In the VT section of the Home Screen. This will activate a connection diagram showing how to correctly connect the MVCT to the VT

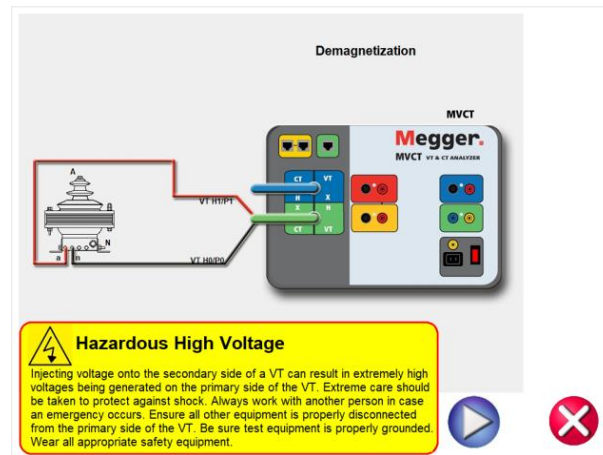


Figure 119 VT Demagnetization Connection Diagram

8. Check all connections to ensure correctness

9. Hit Blue Play button to begin process.



10. The Demagnetization process will begin.

11. At any point of time Test can be terminated by hitting the ABORT button at the top of the screen...

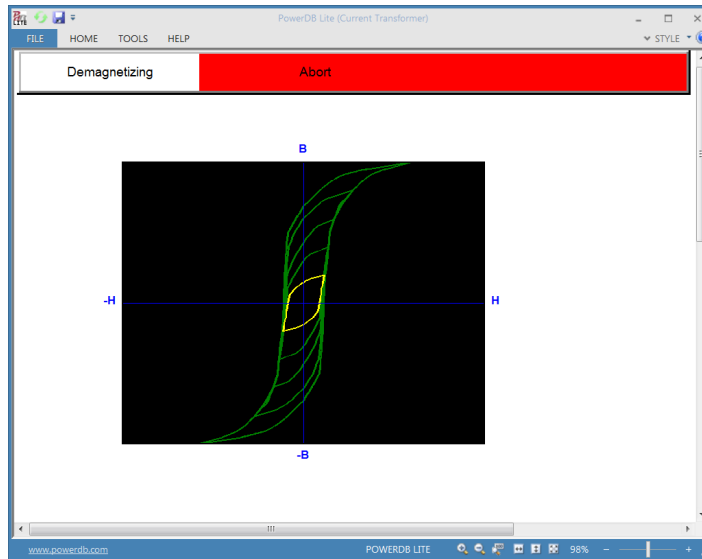


Figure 120 VT Demagnetization Screen –Abort

12. Upon completion of process the VT will be left in a demagnetized state

Demagnetization process is performed on an instrument transformer to remove any magnetizing forces on the windings that can effect the accuracy and performance of the instrument transformer

7.7 Testing Voltage Transformer: Self Diagnostic

Refer to the safety instructions first before use of the equipment.

10. Verify the Power ON/OFF switch is OFF. Power the test set from a suitable source of power (95-125 or 195-265 V50/60 Hz).
11. Connect the ground wing nut to a suitable ground.

WARNING

There is always the possibility of voltages being induced at the terminals of a test specimen because of proximity to high voltage energized lines. A residual static voltage charge may also be present at these terminals. Ground each terminal to be tested with a safety ground stick, before making connections.

WARNING

The MVCT produces high voltages and currents during the performance of tests. DO NOT TOUCH connector clips or test leads while the MVCT is performing a test.

12. Turn Power ON/OFF switch to ON.
13. After the boot up, in the Home Screen, place the MVCT in voltage transformer testing mode by selecting the VT button at the top of the screen.



14. Select the "Self Diagnostic" button
15. The following connection diagram will appear. Ensure the MVCT is connected properly.

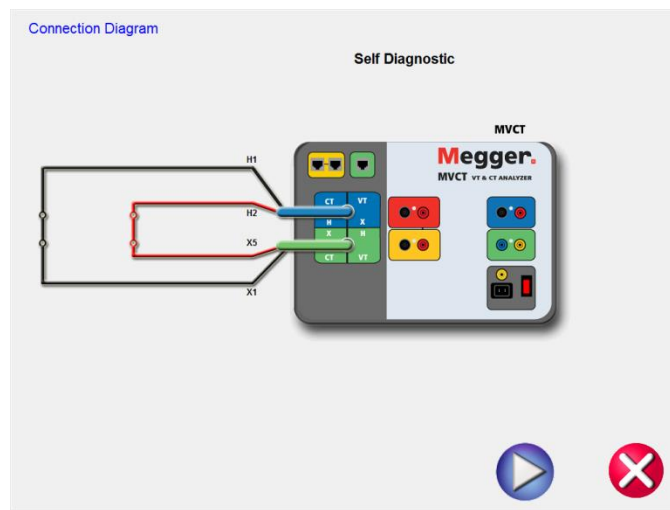


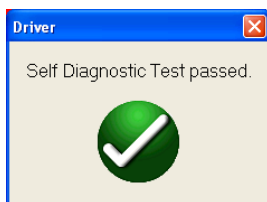
Figure 121 Self Diagnostic Connection Diagram

16. During the Self Test, Secondary Current, Secondary Voltage and Primary Voltage will be displayed

Self testing		ABORT	
Current (A)	Voltage (V)	H Voltage(V)	
0.100	0.300	0.300	

Figure 122 Self Diagnostic Test Screen

17. After the unit has checked the voltage and current generators and meters are working properly, the user will be advised the unit has passed or failed the test



8.0 Testing Relays with MVCT

For proper operation and control of the relay testing functionality, please refer to the User Guide for Megger's SMRT1 Single Phase Relay Test System

9.0 Service Data

9.1 Preventive Maintenance

The unit utilizes surface mount technology (SMT) and other components which require little or no service except for routine cleaning, etc. The unit should be serviced in a clean atmosphere away from energized electrical circuits.

9.1.1 Examine the unit every six months for:

Dust and Dirt	To clean the unit, never use spray liquids or industrial cleaners. Some cleaning solvents can damage electrical components, and should never be used. Use a lightly damp cloth (not dripping wet) to wipe off the unit. Remove dust with dry, low pressure, compressed air.
Moisture	Remove moisture as much as possible by putting the test set in a warm, dry environment.

9.1.2 Upgrading Software

Upgrade via Megger Website

To download the newest STVI software from the Megger website,

1. Get the serial number of your unit.
2. Go to WWW.Megger.com
3. **Log In.** If you have not registered before you will need to do so first.
4. Go to **Software Downloads**
5. Click on **STVI**
6. You will see instructions to enter the serial number of the STVI unit, and then click on **Continue**. The serial number is 12 digits long. Make sure you enter all 12 digits. There will be two versions of the software. One is for your PC and one is for the STVI. For the STVI unit, go to the **STVI software for STVI Installation or Upgrade** and press on the Click Here link. The software will be downloaded onto your PC as a zip file. Unzip the file, **Select All** files, and **Copy** to a USB memory stick, or create a file on your PC for storage to unzip or extract to a file.

Upgrade via Compact Disk

Where internet access may not be available or blocked on your computer, Megger can provide a CD with the latest version of software on it. Contact your local Megger representative to order a copy of the firmware.

How to Download STVI Software into STVI


USB Memory Stick: With the STVI powered up, insert the USB memory stick into the USB port on top of the STVI. If the Windows "Removable Disk (E)" Explorer screen appears, press the Cancel button, and then go to the STVI Configuration Screen and press the Update Firmware button. Press the "STVI Firmware" button. A window will appear stating that there is a software upgrade available and will ask if

you want to execute the upgrade. Press Yes and the unit will automatically upgrade the software. When complete, power down the STVI by disconnecting the Ethernet cable. Wait about 5 to 10 seconds and reconnect the cable. Observe the STVI display screen. When the basic test screen appears, press the Configuration button, then press the Display Versions button and verify the version of the software upgrade.

9.2 Service and Repair Instructions


Basic troubleshooting information has been provided to guide the technician to the possible source of a problem.

Since the STVI uses Surface Mount Technology, repairs of the individual printed circuit boards are beyond the scope of the basic troubleshooting guide, and should be referred to the Service Department at Megger or handled through the Megger Representative.

 If the unit is still within the original warranty period, or limited warranty period following factory servicing, **the factory must be contacted before attempting any repairs or the warranty will be void.**

9.2.1 Basic Troubleshooting


The troubleshooting information relies on the technician to have a good understanding of the operation of the unit. The technician should contact the factory should they have any questions regarding the operation of the unit. Provide the Megger the serial number of the STVI when making inquiries.

 **WARNING** It is necessary to energize the MVCT to properly troubleshoot the STVI. The technician must take all applicable safety precautions for working with the possible energized outputs of the MVCT.

NOTES

Before suspecting a failure in the STVI review the Description of Controls and Theory of Operation sections to ensure that the problem is not a result of operating error.

Common causes of malfunctions, other than improper operation, are bad Ethernet cable or cable connectors, or incorrect power input (voltage above or below specified limits).

 **NOTE:** Under no circumstance should the technician take the STVI apart without following proper ESD protection and handling procedures. Failure to do so, will damage sensitive parts.

9.2.1.1 Power Input

Input voltage affects the whole unit, including the 48 Volts DC to the STVI from the PoE port, and may or may not cause permanent damage if voltage is incorrect. These problems can often be corrected by simply using a better source of input power. See unit front panel for input voltage rating.


Some symptoms are as follows:

1. Low voltage: Erratic operation, no display, or a dim display.
2. High voltage: Circuit breaker operation on MVCT unit, power supply failure.
 - a. For MVCT, the internal power supply needs to be repaired or replaced, contact the factory for further instructions.

9.2.1.2 Ethernet Cable

Basic troubleshooting of the Ethernet communication cable as follows,


1. No power: Check power source and line cord. If the MVCT powers up, but the STVI display does light up, check the cable and cable connectors. Typical problem is usually a broken conductor or cracked cable connector. Replace cable to see if this resolves issue.
2. Erratic Manual Control
 - A. Communication cable is not properly connected, thus cannot receive proper commands.
 - B. Internal problem with communications inside the MVCT

 Contact the factory for a Repair Authorization Number and return instructions if service is required. A Repair Authorization (RA) number will be assigned for proper handling of the unit when it arrives at the factory. Any non-warranty repair cost incurred for the repair or replacement of parts and/or materials shall be the responsibility of the purchaser.

Provide the factory with model number, Unit serial number, nature of the problem or service required, return address, your name, and how to contact you should the factory need to discuss the service request.


You may need to provide a purchase order number, cost limit, billing, and return shipping instructions. If an estimate is requested, provide the name and contact information.

10.0 Preparation for Reshipment

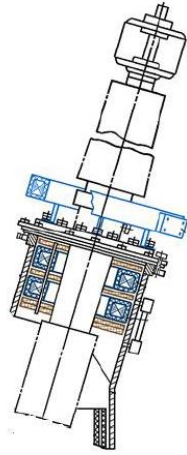
 Save the original shipping container for future use. The shipping container is designed to withstand the rigors of shipping via a common commercial carrier.

Pack the equipment appropriately to prevent damage during shipment. If a reusable container is utilized, the unit will be returned in the same shipping container if it is in suitable condition.

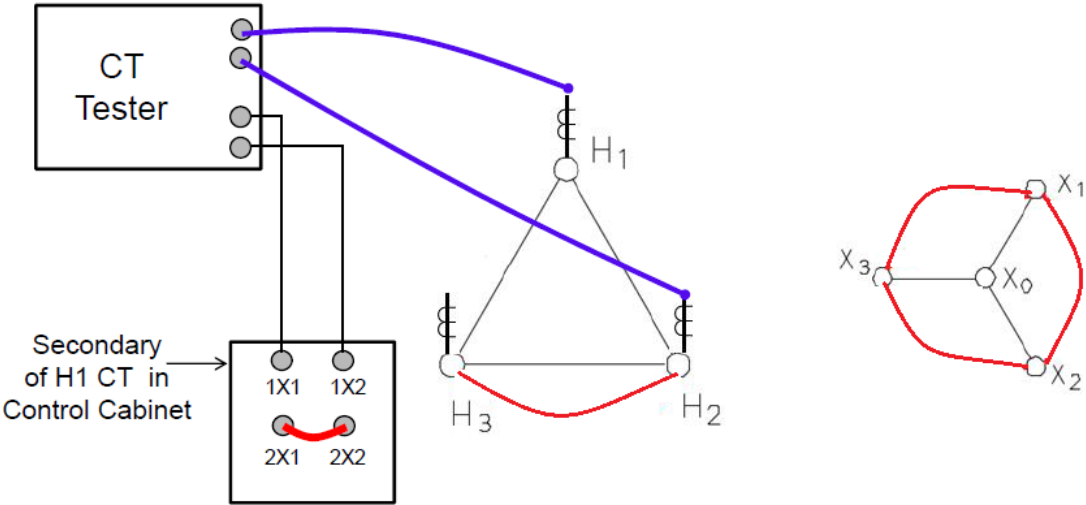
Add the Return Authorization Number to the address label of the shipping container for proper identification and quicker handling.

 NOTE: Ship the equipment without nonessential items such as test leads, etc. These items are not needed by the factory to perform service.

Appendix I CTs Mounted on Transformer Bushings

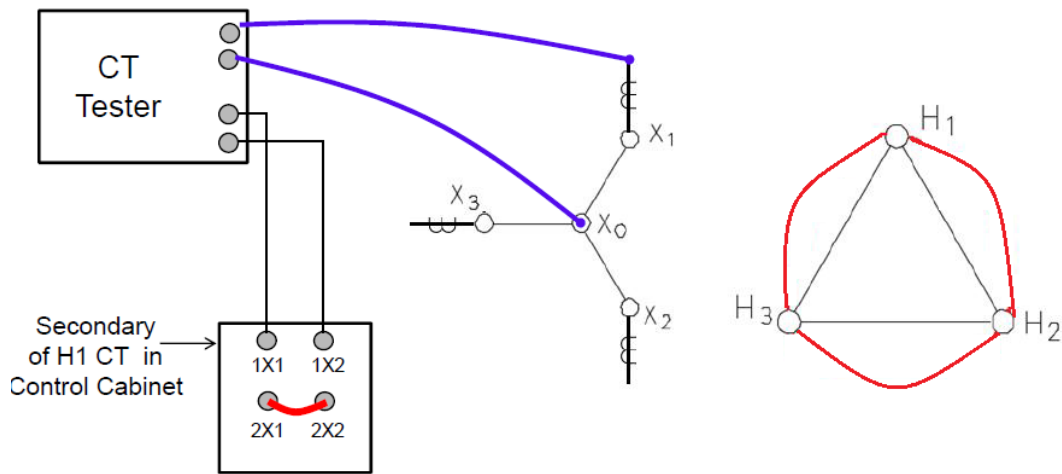


BCTs mounted on Δ Winding Transformer (HV Side)



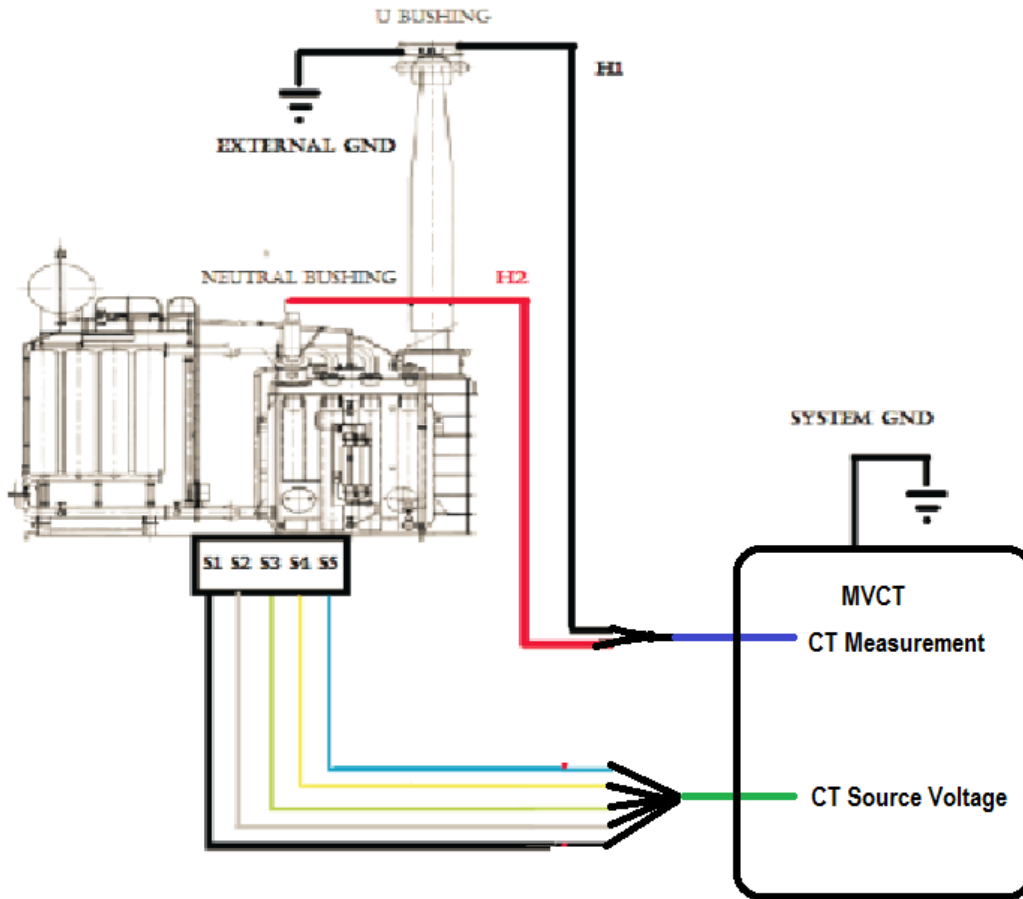
CT Locations	Tests Set Connections			Jumpers
	X1 X2	H1	H2	
H1 Bushing	Secondary of H1 CT located in control cabinet	H1 Bushing	H2 Bushing	H2 - H3 X1 - X2 - X3
H2 Bushing	Secondary of H2 CT located in control cabinet	H2 Bushing	H3 Bushing	H3 - H1 X1 - X2 - X3
H3 Bushing	Secondary of H3 CT located in control cabinet	H3 Bushing	H1 Bushing	H1 - H2 X1 - X2 - X3

BCTs mounted on Y Winding Transformer (LV Side)



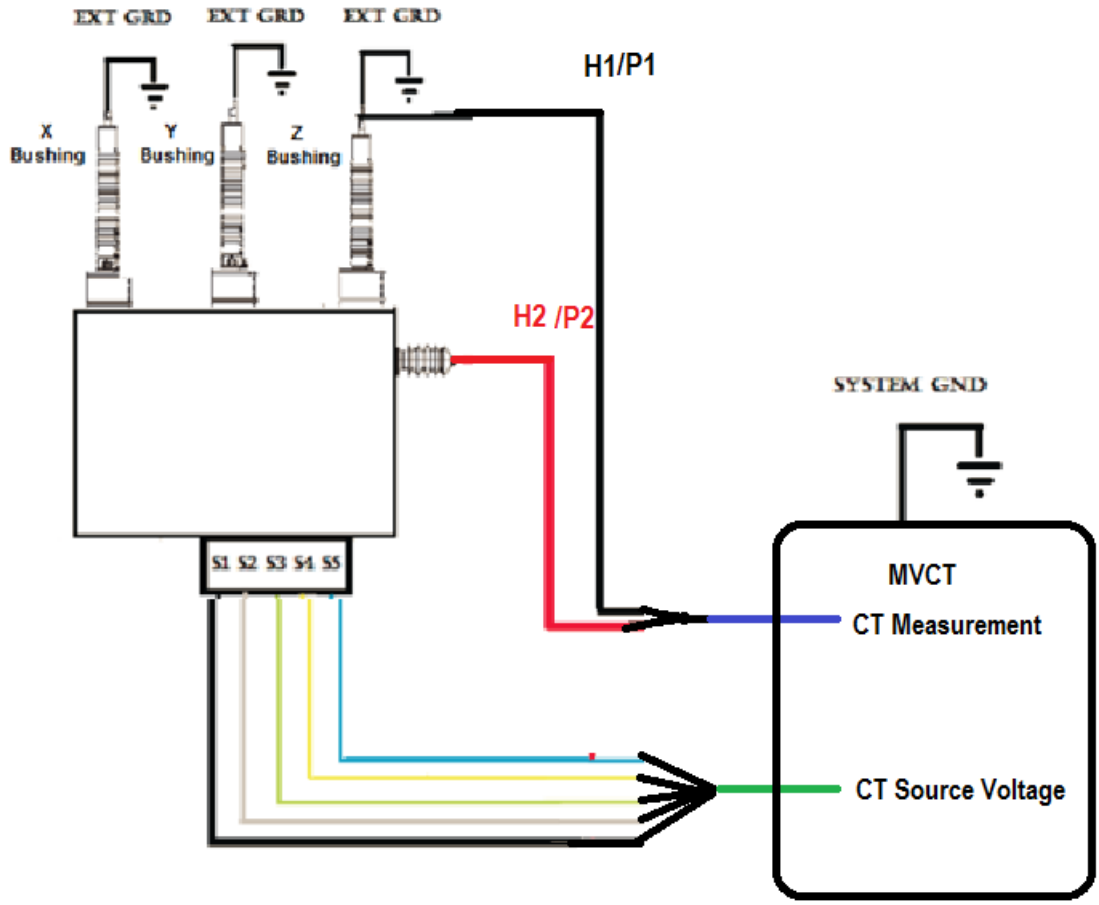
CT Locations	Tests Set Connections			Jumpers
	X1 X2	H1	H2	
X1 Bushing	Secondary of X1 CT located in control cabinet	X1 Bushing	Neutral Bushing	H1 - H2 - H3
X2 Bushing	Secondary of X2 CT located in control cabinet	X2 Bushing	Neutral Bushing	H1 - H2 - H3
X3 Bushing	Secondary of X3 CT located in control cabinet	X3 Bushing	Neutral Bushing	H1 - H2 - H3

Appendix II Testing CT in Reactor



Connection Diagram Single Phase Reactor

CT Locations	Tests Set Connections			Jumpers
	X1	X2	H2	
Neutral Bushing	Secondary of CT located in control cabinet	H1	Neutral Bushing	All CT not under Test
U Bushing	Secondary of CT located in control cabinet	U Bushing	Neutral Bushing	All CT not under Test

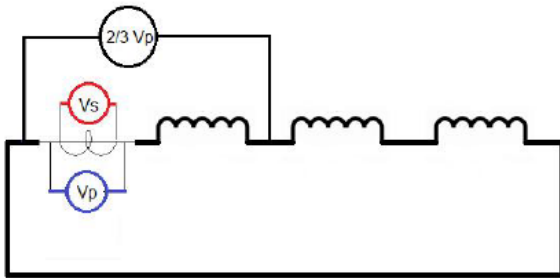


Connection Diagram Three Phase Reactor

CT Locations	Tests Set Connections			
	X1 X2	H1	H2	Jumpers
X Bushing	Secondary of CT located in control cabinet	X Bushing	Neutral Bushing	All CT not under Test X Bushing - GND Y Bushing - GND Z Bushing - GND
Y Bushing	Secondary of CT located in control cabinet	Y Bushing	Neutral Bushing	All CT not under Test X Bushing - GND Y Bushing - GND Z Bushing - GND
Z Bushing	Secondary of CT located in control cabinet	Z Bushing	Neutral Bushing	All CT not under Test X Bushing - GND Y Bushing - GND Z Bushing - GND

Appendix III CTs Inside Delta Connection

Ratio of CTs Inside the Δ connection of a Transformer



- During a ratio test, a voltage is applied to the terminals of the CT and a voltage is induced at the primary
- In this case the primary is a Δ
- Induced voltage divides among the three windings in the Δ , in equal parts
- Actual measured ratio is $2/3$ of the primary voltage:
 - Calculated automatically by the instrument
 - Manually by the operator